

## ADSP-21261/ADSP-21262/ADSP-21266

### SUMMARY

High performance 32-bit/40-bit floating-point processor optimized for high performance audio processing

Code compatibility—at assembly level, uses the same instruction set as other SHARC DSPs

Processes high performance audio while enabling low system costs

Audio decoders and postprocessor algorithms support nonvolatile memory that can be configured to contain a combination of PCM 96 kHz, Dolby® Digital, Dolby Digital Surround EX™, DTS-ES™ Discrete 6.1, DTS-ES Matrix 6.1, DTS® 96/24 5.1, MPEG2 AAC LC, MPEG2 BC 2ch, WMA-PRO V7.1, Dolby Pro Logic II, Dolby Pro Logic 2x, and DTS Neo:6™

Various multichannel surround sound decoders are contained in ROM. For configurations of decoder algorithms, see [Table 3 on Page 6](#).

Single-instruction multiple-data (SIMD) computational architecture—two 32-bit IEEE floating-point/32-bit fixed-point/40-bit extended precision floating-point computational units, each with a multiplier, ALU, shifter, and register file

High bandwidth I/O—a parallel port, an SPI port, 6 serial ports, a digital audio interface (DAI), and JTAG

DAI incorporates two precision clock generators (PCGs), an input data port (IDP) that includes a parallel data acquisition port (PDAP), and 3 programmable timers, all under software control by the signal routing unit (SRU)

On-chip memory—up to 2M bits on-chip SRAM and a dedicated 4M bits on-chip mask-programmable ROM

The ADSP-2126x processors are available with a 150 MHz or a 200 MHz core instruction rate. For complete ordering information, see [Ordering Guide on Page 47](#).

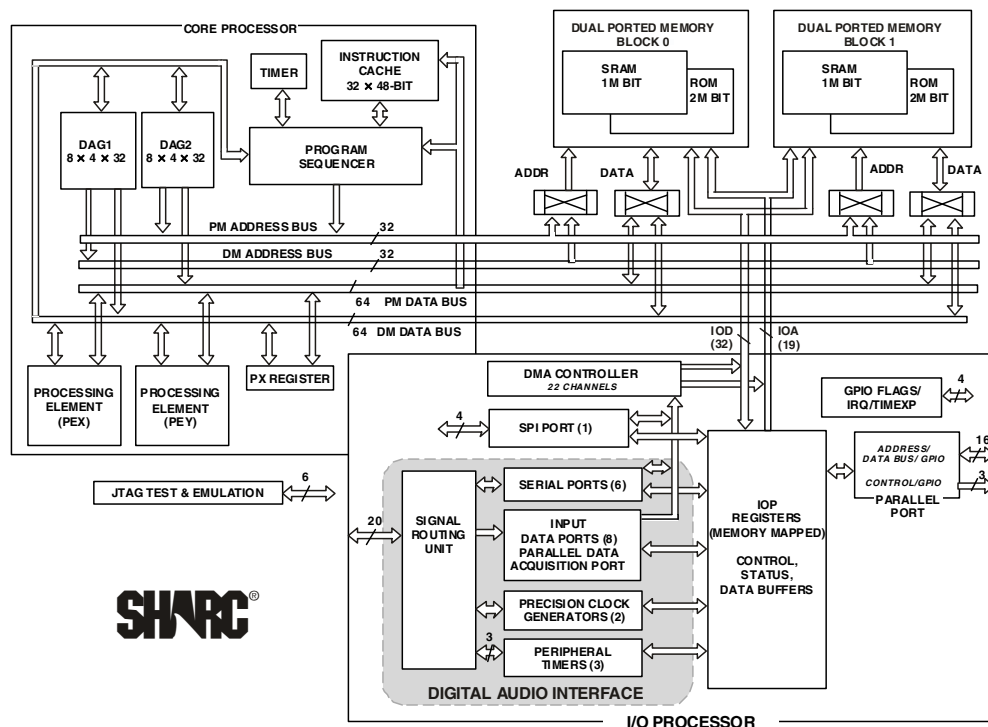

Figure 1. Functional Block Diagram

SHARC and the SHARC logo are registered trademarks of Analog Devices, Inc.

### Rev. E

Information furnished by Analog Devices is believed to be accurate and reliable. However, no responsibility is assumed by Analog Devices for its use, nor for any infringements of patents or other rights of third parties that may result from its use. Specifications subject to change without notice. No license is granted by implication or otherwise under any patent or patent rights of Analog Devices. Trademarks and registered trademarks are the property of their respective owners.

# ADSP-21261/ADSP-21262/ADSP-21266

## KEY FEATURES

Serial ports offer left-justified sample-pair and I<sup>2</sup>S support via 12 programmable and simultaneous receive or transmit pins, which support up to 24 transmit or 24 receive I<sup>2</sup>S channels of audio when all 6 serial ports (SPORTs) are enabled or 6 full duplex TDM streams of up to 128 channels per frame

At 200 MHz (5 ns) core instruction rate, the ADSP-2126x operates at 1200 MFLOPS peak/800 MFLOPS sustained performance whether operating on fixed- or floating-point data; 400 MMACS sustained performance at 200 MHz

Super Harvard Architecture—3 independent buses for dual data fetch, instruction fetch, and nonintrusive, zero-overhead I/O

Up to 2M bits on-chip dual-ported SRAM (1M bit block 0, 1M bit block 1) for simultaneous access by core processor and DMA

Up to 4M bits on-chip dual-ported mask-programmable ROM (2M bits in block 0 and 2M bits in block 1)

Dual data address generators (DAGs) with modulo and bit-reverse addressing

Zero-overhead looping with single-cycle loop setup, providing efficient program sequencing

Single instruction multiple data (SIMD) architecture provides 2 computational processing elements

Concurrent execution—each processing element executes the same instruction, but operates on different data

Parallelism in buses and computational units allows single cycle executions (with or without SIMD) of a multiply operation; an ALU operation; a dual memory read or write; and an instruction fetch

Transfers between memory and core at up to four 32-bit floating- or fixed-point words per cycle, sustained 2.4 Gbps bandwidth at 200 MHz core instruction rate; 900 Mbps is available via DMA

Accelerated FFT butterfly computation through a multiply with add and subtract instruction

DMA controller supports

Up to 22 zero-overhead DMA channels for transfers between the ADSP-2126x internal memory and serial ports (12), the input data ports (IDP) (8), the SPI-compatible port (1), and the parallel port (1)

32-bit background DMA transfers at core clock speed, in parallel with full-speed processor execution

IEEE 1149.1 JTAG standard test access port and on-chip emulation

Dual voltage: 3.3 V I/O, 1.2 V core

Available in 136-ball BGA and 144-lead LQFP packages; available in RoHS compliant packages

Digital audio interface includes 6 serial ports, 2 precision clock generators, an input data port, 3 programmable timers, and a signal routing unit

Asynchronous parallel/external port provides

Access to asynchronous external memory

16 multiplexed address/data lines that can support 24-bit address external address range with 8-bit data or 16-bit address external address range with 16-bit data

66M byte/sec transfer rate for 200 MHz core rate

50M byte/sec transfer rate for 150 MHz core rate

256 word page boundaries

External memory access in a dedicated DMA channel

8- to 32-bit and 16- to 32-bit word packing options

Programmable wait state options: 2 to 31 CCLKs

Serial ports provide

50M bits/sec for a 200 MHz core and up to 37.5M bits/sec for a 150 MHz core on each data line—each has a clock, frame sync, and 2 data lines that can be configured as either a receiver or transmitter pair

Left-justified sample-pair and I<sup>2</sup>S support, programmable direction for up to 24 simultaneous receive or transmit channels (16 channels on the ADSP-21261) using 2 I<sup>2</sup>S-compatible stereo devices per serial port

TDM support for telecommunications interfaces including 128 TDM channel support for newer telephony interfaces such as H.100/H.110

Up to 12 TDM stream support, each with 128 channels per frame

Companding selection on a per channel basis in TDM mode

Input data port provides an additional input path to the SHARC core configurable as either 8 channels of I<sup>2</sup>S or serial data or as 7 channels plus a single 20-bit wide synchronous parallel data acquisition port

Supports receive audio channel data in I<sup>2</sup>S, left-justified sample pair, or right-justified mode

Signal routing unit (SRU) provides configurable and flexible connections between all DAI components, 6 serial ports, two precision clock generators, 3 timers, an input data port/parallel data acquisition port, 10 interrupts, 6 flag inputs, 6 flag outputs, and 20 SRU I/O pins (DAI\_Px)

Serial peripheral interface (SPI)

Master or slave serial boot through SPI

Full-duplex operation

Master-slave mode multimaster support

Open-drain outputs

Programmable baud rates, clock polarities, and phases

3 muxed flag/IRQ lines

1 muxed flag/timer expired line

ROM-based security features:

JTAG access to memory permitted with a 64-bit key

Protected memory regions that can be assigned to limit access under program control to sensitive code

PLL has a wide variety of software and hardware multiplier/divider ratios

**TABLE OF CONTENTS**

Summary ..... 1

Key Features ..... 2

Table of Contents ..... 3

Revision History ..... 3

General Description ..... 4

    Family Core Architecture ..... 5

    Memory and I/O Interface Features ..... 6

    Target Board JTAG Emulator Connector ..... 9

    Development Tools ..... 9

    Evaluation Kit ..... 10

    Designing an Emulator-Compatible DSP Board (Target) 11

    Additional Information ..... 11

Pin Function Descriptions ..... 12

    Address Data Pins as Flags ..... 15

    Core Instruction Rate to CLKIN Ratio Modes ..... 15

    Address Data Modes ..... 15

Product Specifications ..... 16

    Operating Conditions ..... 16

    Electrical Characteristics ..... 16

    Package Information ..... 17

    ESD Caution ..... 17

    Maximum Power Dissipation ..... 17

    Absolute Maximum Ratings ..... 17

    Timing Specifications ..... 17

    Output Drive Currents ..... 39

    Test Conditions ..... 39

    Capacitive Loading ..... 39

    Environmental Conditions ..... 40

    Thermal Characteristics ..... 40

144-Lead LQFP Pin Configurations ..... 41

136-Ball BGA Pin Configurations ..... 42

Outline Dimensions ..... 45

    Surface-Mount Design ..... 45

Ordering Guide ..... 47

**REVISION HISTORY**

7/08—Rev. D to Rev. E

This revision of the data sheet combines the ADSP-21261 and ADSP-21262 into the ADSP-21266 data sheet.

Corrected all outstanding document errata.

Corrected block diagram..... 1

Added Extended Precision Normal or Instruction Word (48 Bits) to [Table 4](#) and [Table 5](#) ..... 7

Revised VCO specification in [Clock Input](#) ..... 20

# ADSP-21261/ADSP-21262/ADSP-21266

## GENERAL DESCRIPTION

The ADSP-21261/ADSP-21262/ADSP-21266 SHARC® DSPs are members of the SIMD SHARC family of DSPs featuring Analog Devices Inc., Super Harvard Architecture. The ADSP-2126x is source code compatible with the ADSP-21160 and ADSP-21161 DSPs as well as with first generation ADSP-2106x SHARC processors in SISD (single-instruction, single-data) mode. Like other SHARC DSPs, the ADSP-2126x are 32-bit/40-bit floating-point processors optimized for high performance audio applications with dual-ported on-chip SRAM, mask-programmable ROM, multiple internal buses to eliminate I/O bottlenecks, and an innovative digital audio interface.

Table 1 shows performance benchmarks for the processors running at 200 MHz. Table 2 shows the features of the individual product offerings.

**Table 1. Processor Benchmarks (at 200 MHz)**

Benchmark Algorithm	Speed (at 200 MHz)
1024 Point Complex FFT (Radix 4, with reversal)	61.3 $\mu$ s
FIR Filter (per tap) <sup>1</sup>	3.3 ns
IIR Filter (per biquad) <sup>1</sup>	13.3 ns
Matrix Multiply (pipelined)	
$[3 \times 3] \times [3 \times 1]$	30 ns
$[4 \times 4] \times [4 \times 1]$	53.3 ns
Divide (y/x)	20 ns
Inverse Square Root	30 ns

<sup>1</sup> Assumes two files in multichannel SIMD mode.

As shown in the functional block diagram in Figure 1 on Page 1, the ADSP-2126x uses two computational units to deliver a 5 to 10 times performance increase over previous SHARC processors on a range of DSP algorithms. Fabricated in a state-of-the-art, high speed, CMOS process, the ADSP-2126x DSPs achieve an instruction cycle time of 5 ns at 200 MHz or 6.6 ns at 150 MHz. With its SIMD computational hardware, the ADSP-2126x can perform 1200 MFLOPS running at 200 MHz, or 900 MFLOPS running at 150 MHz.

**Table 2. ADSP-2126x SHARC Processor Features**

Feature	ADSP-21261	ADSP-21262	ADSP-21266
RAM	1M bit	2M bit	2M bit
ROM	3M bit	4M bit	4M bit
Audio Decoders in ROM <sup>1</sup>	No	No	Yes
DMA Channels	18	22	22
SPORTs	4	6	6
Package	136-ball BGA 144-lead LQFP	136-ball BGA 144-lead LQFP	136-ball BGA 144-lead LQFP

<sup>1</sup> For information on available audio decoding algorithms, see Table 3 on Page 6.

The ADSP-2126x continues SHARC's industry-leading standards of integration for DSPs, combining a high performance 32-bit DSP core with integrated, on-chip system features. These features include 2M bit dual-ported SRAM memory, 4M bit dual-ported ROM, an I/O processor that supports 22 DMA channels, six serial ports, an SPI interface, external parallel bus, and digital audio interface.

The block diagram of the ADSP-2126x on Page 1 illustrates the following architectural features:

- Two processing elements, each containing an ALU, multiplier, shifter, and data register file
- Data address generators (DAG1, DAG2)
- Program sequencer with instruction cache
- PM and DM buses capable of supporting four 32-bit data transfers between memory and the core at every core processor cycle
- Three programmable interval timers with PWM generation, PWM capture/pulse width measurement, and external event counter capabilities
- On-chip dual-ported SRAM (up to 2M bit)
- On-chip dual-ported, mask-programmable ROM (up to 4M bit)
- JTAG test access port
- 8- or 16-bit parallel port that supports interfaces to off-chip memory peripherals
- DMA controller
- Six full-duplex serial ports (four on the ADSP-21261)
- SPI-compatible interface
- Digital audio interface that includes two precision clock generators (PCG), an input data port (IDP), six serial ports, eight serial interfaces, a 20-bit synchronous parallel input port, 10 interrupts, six flag outputs, six flag inputs, three programmable timers, and a flexible signal routing unit (SRU)

Figure 2 shows one sample configuration of a SPORT using the precision clock generator to interface with an I<sup>2</sup>S ADC and an I<sup>2</sup>S DAC with a much lower jitter clock than the serial port would generate itself. Many other SRU configurations are possible.

## FAMILY CORE ARCHITECTURE

The ADSP-2126x is code compatible at the assembly level with the ADSP-2136x and ADSP-2116x, and with the first generation ADSP-2106x SHARC DSPs. The ADSP-2126x shares architectural features with the ADSP-2136x and ADSP-2116x SIMD SHARC family of DSPs, as detailed in the following sections.

### SIMD Computational Engine

The ADSP-2126x contain two computational processing elements that operate as a single-instruction multiple-data (SIMD) engine. The processing elements are referred to as PEX and PEY

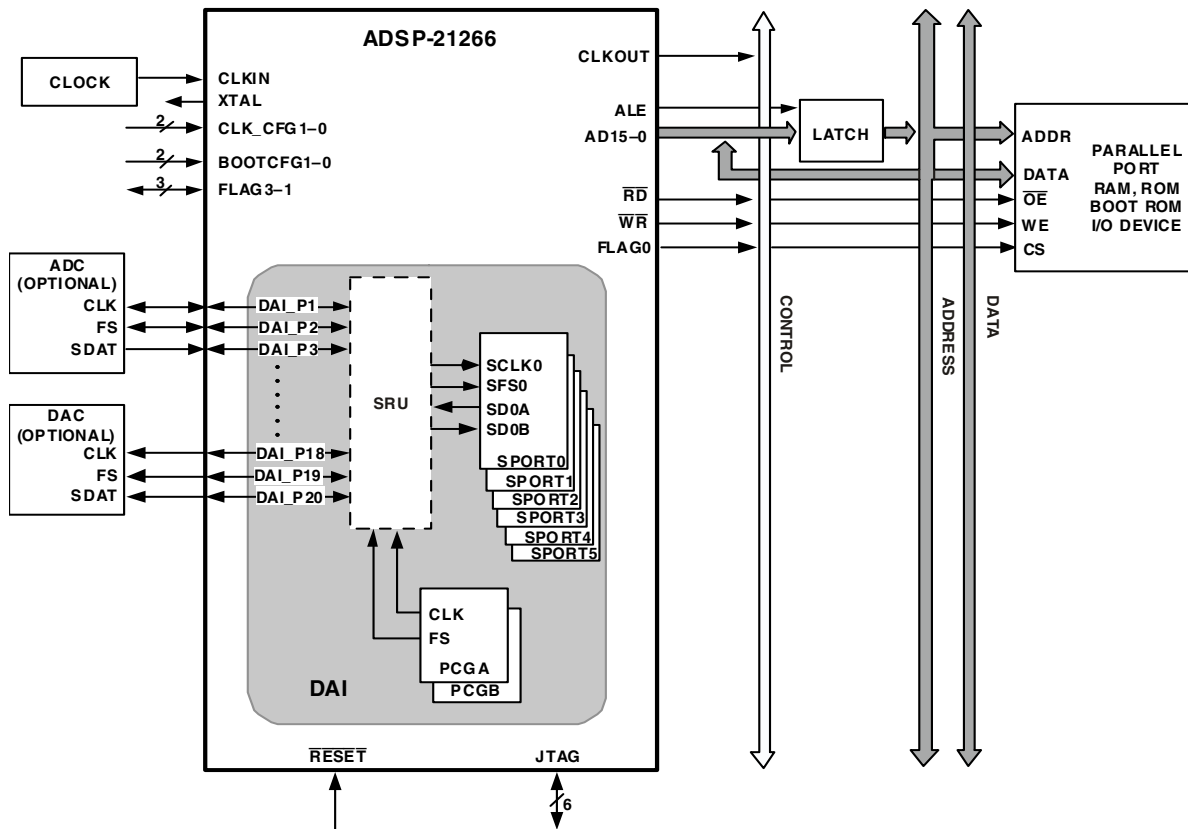

Figure 2. ADSP-21266 System Sample Configuration

and each contains an ALU, multiplier, shifter, and register file. PEX is always active, and PEY can be enabled by setting the PEYEN mode bit in the MODE1 register. When this mode is enabled, the same instruction is executed in both processing elements, but each processing element operates on different data. This architecture is efficient at executing math intensive audio algorithms.

Entering SIMD mode also has an effect on the way data is transferred between memory and the processing elements. When in SIMD mode, twice the data bandwidth is required to sustain computational operation in the processing elements. Because of this requirement, entering SIMD mode also doubles the bandwidth between memory and the processing elements. When using the DAGs to transfer data in SIMD mode, two data values are transferred with each access of memory or the register file.

### Independent, Parallel Computation Units

Within each processing element is a set of computational units. The computational units consist of an arithmetic/logic unit (ALU), multiplier, and shifter. These units perform all operations in a single cycle. The three units within each processing element are arranged in parallel, maximizing computational throughput. Single multifunction instructions execute parallel ALU and multiplier operations. In SIMD mode, the parallel ALU and multiplier operations occur in both processing

elements. These computation units support IEEE 32-bit single precision floating-point, 40-bit extended precision floating-point, and 32-bit fixed-point data formats.

### Data Register File

A general-purpose data register file is contained in each processing element. The register files transfer data between the computation units and the data buses, and store intermediate results. These 10-port, 32-register (16 primary, 16 secondary) register files, combined with the ADSP-2126x enhanced Harvard architecture, allow unconstrained data flow between computation units and internal memory. The registers in PEX are referred to as R0–R15 and in PEY as S0–S15.

### Single-Cycle Fetch of Instruction and Four Operands

The ADSP-2126x features an enhanced Harvard architecture in which the data memory (DM) bus transfers data and the program memory (PM) bus transfers both instructions and data (see Figure 1 on Page 1). With the ADSP-2126x's separate program and data memory buses and on-chip instruction cache, the processor can simultaneously fetch four operands (two over each data bus) and one instruction (from the cache), all in a single cycle.

# ADSP-21261/ADSP-21262/ADSP-21266

## Instruction Cache

The ADSP-2126x includes an on-chip instruction cache that enables three-bus operation to fetch an instruction and four data values. The cache is selective—only the instructions whose fetches conflict with PM bus data accesses are cached. This cache allows full-speed execution of core, looped operations such as digital filter multiply-accumulates, and FFT butterfly processing.

## Data Address Generators with Zero-Overhead Hardware Circular Buffer Support

The ADSP-2126x's two data address generators (DAGs) are used for indirect addressing and implementing circular data buffers in hardware. Circular buffers allow efficient programming of delay lines and other data structures required in digital signal processing, and are commonly used in digital filters and Fourier transforms. The two DAGs of the ADSP-2126x contain sufficient registers to allow the creation of up to 32 circular buffers (16 primary register sets, 16 secondary). The DAGs automatically handle address pointer wraparound, reduce overhead, increase performance, and simplify implementation. Circular buffers can start and end at any memory location.

## Flexible Instruction Set

The 48-bit instruction word accommodates a variety of parallel operations for concise programming. For example, the ADSP-2126x can conditionally execute a multiply, an add, and a subtract in both processing elements while branching and fetching up to four 32-bit values from memory—all in a single instruction.

## MEMORY AND I/O INTERFACE FEATURES

The ADSP-2126x adds the following architectural features to the SIMD SHARC family core:

### Dual-Ported On-Chip Memory

The ADSP-21262 and ADSP-21266 contain two megabits of internal SRAM and four megabits of internal mask-programmable ROM. The ADSP-21261 contain one megabit of internal SRAM and three megabits of internal mask-programmable ROM. Each block can be configured for different combinations of code and data storage (see memory maps, [Table 4](#) and [Table 5](#)). Each memory block is dual-ported for single-cycle, independent accesses by the core processor and I/O processor. The dual-ported memory, in combination with three separate on-chip buses, allows two data transfers from the core and one from the I/O processor, in a single cycle.

The ADSP-2126x is available with a variety of multichannel surround sound decoders, preprogrammed in ROM memory. [Table 3](#) shows the configuration of decoder algorithms.

**Table 3. Multichannel Surround Sound Decoder Algorithms in On-Chip ROM**

Algorithms	B ROM	C ROM	D ROM
PCM	Yes	Yes	Yes
AC-3	Yes	Yes	Yes
DTS 96/24	v2.2	v2.3	v2.3
AAC (LC)	Yes	Yes	Coefficients only
WMA PRO 7.1 96 KHz	No	No	Yes
MPEG2 BC 2ch	Yes	Yes	No
Noise	Yes	Yes	Yes
DPL2x/EX	DPL2	Yes	Yes
Neo:6/ES (v2.5046)	Yes	Yes	Yes

The ADSP-2126x's SRAM can be configured as a maximum of 64K words of 32-bit data, 128K words of 16-bit data, 42K words of 48-bit instructions (or 40-bit data), or combinations of different word sizes up to two megabits. All of the memory can be accessed as 16-bit, 32-bit, 48-bit, or 64-bit words. A 16-bit floating-point storage format is supported that effectively doubles the amount of data that can be stored on-chip. Conversion between the 32-bit floating-point and 16-bit floating-point formats is performed in a single instruction. While each memory block can store combinations of code and data, accesses are most efficient when one block stores data using the DM bus for transfers, and the other block stores instructions and data using the PM bus for transfers.

Using the DM bus and PM buses, with one dedicated to each memory block, assures single-cycle execution with two data transfers. In this case, the instruction must be available in the cache.

**Table 4. Internal Memory Space (ADSP-21261)**

<b>IOP Registers 0x0000 0000–0003 FFFF</b>			
<b>Long Word (64 Bits)</b>	<b>Extended Precision Normal or Instruction Word (48 Bits)</b>	<b>Normal Word (32 Bits)</b>	<b>Short Word (16 Bits)</b>
Block 0 SRAM 0x0004 0000–0x0004 1FFF	Block 0 SRAM 0x0008 0000–0x0008 2AAA	Block 0 SRAM 0x0008 0000–0x0008 3FFF	Block 0 SRAM 0x0010 0000–0x0010 7FFF
Reserved 0x0004 2000–0x0005 7FFF	Reserved	Reserved 0x0008 4000–0x000A FFFF	Reserved 0x0010 8000–0x0015 FFFF
Block 0 ROM 0x0005 8000–0x0002 FFFF	Block 0 ROM 0x000A 0000–0x000A 7FFF	Block 0 ROM 0x000B 0000–0x000B BFFF	Block 0 ROM 0x0016 0000–0x0017 7FFF
Reserved 0x0005 3000–0x0005 FFFF	Reserved	Reserved 0x000B C000–0x000B FFFF	Reserved 0x0017 8FFF–0x0017 FFFF
Block 1 SRAM 0x0006 0000–0x0006 1FFF	Block 1 SRAM 0x000C 0000–0x000C 2AAA	Block 1 SRAM 0x000C 0000–0x000C 3FFF	Block 1 SRAM 0x0018 0000–0x0018 7FFF
Reserved 0x0006 2000–0x0007 7FFF	Reserved	Reserved 0x000C 4000–0x000E FFFF	Reserved 0x0018 8000–0x001D FFFF
Block 1 ROM 0x0007 8000–0x0007 DFFF	Block 1 ROM 0x000E 0000–0x000E 7FFF	Block 1 ROM 0x000F 0000–0x000F BFFF	Block 1 ROM 0x001E 0000–0x001F 7FFF
Reserved 0x0007 E000–0x0007 FFFF	Reserved	Reserved 0x000F C000–0x000F FFFF	Reserved 0x0000

**Table 5. Internal Memory Space (ADSP-21262/ADSP-21266)**

<b>IOP Registers 0x0000 0000–0003 FFFF</b>			
<b>Long Word (64 Bits)</b>	<b>Extended Precision Normal or Instruction Word (48 Bits)</b>	<b>Normal Word (32 Bits)</b>	<b>Short Word (16 Bits)</b>
Block 0 SRAM 0x0004 0000–0x0004 3FFF	Block 0 SRAM 0x0008 0000–0x0008 5555	Block 0 SRAM 0x0008 0000–0x0008 7FFF	Block 0 SRAM 0x0010 0000–0x0010 FFFF
Reserved 0x0004 4000–0x0005 7FFF	Reserved	Reserved 0x0008 8000–0x000A FFFF	Reserved 0x0011 0000–0x0015 FFFF
Block 0 ROM 0x0005 8000–0x0005 FFFF	Block 0 ROM 0x000A 0000–0x000A AAAA	Block 0 ROM 0x000B 0000–0x000B FFFF	Block 0 ROM 0x0016 0000–0x0017 FFFF
Block 1 SRAM 0x0006 0000–0x0006 3FFF	Block 1 SRAM 0x000C 0000–0x000C 5555	Block 1 SRAM 0x000C 0000–0x000C 7FFF	Block 1 SRAM 0x0018 0000–0x0018 FFFF
Reserved 0x0006 4000–0x0007 7FFF	Reserved	Reserved 0x000C 8000–0x000E FFFF	Reserved 0x0019 0000–0x001D FFFF
Block 1 ROM 0x0007 8000–0x0007 FFFF	Block 1 ROM 0x000E 0000–0x000E AAAA	Block 1 ROM 0x000F 0000–0x000F FFFF	Block 1 ROM 0x001E 0000–0x001F FFFF

### **DMA Controller**

The ADSP-2126x’s on-chip DMA controller allows zero-overhead data transfers without processor intervention. The DMA controller operates independently and invisibly to the processor core, allowing DMA operations to occur while the core is simultaneously executing its program instructions. DMA transfers can occur between the ADSP-2126x’s internal memory and its serial ports, the SPI-compatible (serial peripheral interface) port, the IDP (input data port), parallel data acquisition port (PDAP), or the parallel port. Up to 22 channels of DMA are available on the ADSP-2126x—one for the SPI interface, 12 via

the serial ports, eight via the input data port, and one via the processor’s parallel port. Programs can be downloaded to the ADSP-2126x using DMA transfers. Other DMA features include interrupt generation upon completion of DMA transfers, and DMA chaining for automatic linked DMA transfers.

### **Digital Audio Interface (DAI)**

The digital audio interface provides the ability to connect various peripherals to any of the SHARC DSP’s DAI pins (DAI\_P20–1).

# ADSP-21261/ADSP-21262/ADSP-21266

Connections are made using the signal routing unit (SRU, shown in the block diagram on Page 1).

The SRU is a matrix routing unit (or group of multiplexers) that enables the peripherals provided by the DAI to be interconnected under software control. This allows easy use of the DAI associated peripherals for a much wider variety of applications by using a larger set of algorithms than is possible with nonconfigurable signal paths.

The DAI also includes six serial ports, two precision clock generators (PCGs), an input data port (IDP), six flag outputs and six flag inputs, and three timers. The IDP provides an additional input path to the ADSP-2126x core, configurable as either eight channels of I<sup>2</sup>S or serial data, or as seven channels plus a single 20-bit wide synchronous parallel data acquisition port. Each data channel has its own DMA channel that is independent from the ADSP-2126x's serial ports.

For complete information on using the DAI, see the *ADSP-2126x SHARC DSP Peripherals Manual*.

## Serial Ports

The ADSP-2126x features six full duplex synchronous serial ports that provide an inexpensive interface to a wide variety of digital and mixed-signal peripheral devices such as the Analog Devices AD183x family of audio codecs, ADCs, and DACs. The serial ports are made up of two data lines, a clock, and frame sync. The data lines can be programmed to either transmit or receive and each data line has its own dedicated DMA channel.

Serial ports are enabled via 12 programmable and simultaneous receive or transmit pins that support up to 24 transmit or 24 receive channels of audio data when all six SPORTs are enabled, or six full duplex TDM streams of 128 channels per frame.

The serial ports operate at up to one-quarter of the DSP core clock rate, providing each with a maximum data rate of 50M bits/sec for a 200 MHz core and 37.5M bits/sec for a 150 MHz core. Serial port data can be automatically transferred to and from on-chip memory via a dedicated DMA. Each of the serial ports can work in conjunction with another serial port to provide TDM support. One SPORT provides two transmit signals while the other SPORT provides two receive signals. The frame sync and clock are shared.

Serial ports operate in four modes:

- Standard DSP serial mode
- Multichannel (TDM) mode
- I<sup>2</sup>S mode
- Left-justified sample pair mode

Left-justified sample pair mode is a mode where in each frame sync cycle, two samples of data are transmitted/received—one sample on the high segment of the frame sync, the other on the low segment of the frame sync. Programs have control over various attributes of this mode.

Each of the serial ports supports the left-justified sample-pair and I<sup>2</sup>S protocols (I<sup>2</sup>S is an industry-standard interface commonly used by audio codecs, ADCs, and DACs) with two data pins, allowing four left-justified sample-pair or I<sup>2</sup>S channels

(using two stereo devices) per serial port with a maximum of up to 24 audio channels. The serial ports permit little-endian or big-endian transmission formats and word lengths selectable from 3 bits to 32 bits. For the left-justified sample pair and I<sup>2</sup>S modes, data-word lengths are selectable between 8 bits and 32 bits. Serial ports offer selectable synchronization and transmit modes as well as optional  $\mu$ -law or A-law companding selection on a per channel basis. Serial port clocks and frame syncs can be internally or externally generated.

## Serial Peripheral (Compatible) Interface

The serial peripheral interface is an industry-standard synchronous serial link, enabling the ADSP-2126x SPI-compatible port to communicate with other SPI-compatible devices. SPI is an interface consisting of two data pins, one device select pin, and one clock pin. It is a full-duplex synchronous serial interface, supporting both master and slave modes. The SPI port can operate in a multimaster environment by interfacing with up to four other SPI-compatible devices, either acting as a master or slave device. The ADSP-2126x SPI-compatible peripheral implementation also features programmable baud rates at up to 50 MHz for a core clock of 200 MHz and up to 37.5 MHz for a core clock of 150 MHz, clock phases, and polarities. The ADSP-2126x SPI-compatible port uses open-drain drivers to support a multimaster configuration and to avoid data contention.

## Parallel Port

The parallel port provides interfaces to SRAM and peripheral devices. The multiplexed address and data pins (AD15–0) can access 8-bit devices with up to 24 bits of address, or 16-bit devices with up to 16 bits of address. In either mode, 8- or 16-bit, the maximum data transfer rate is one-third the core clock speed. As an example, a clock rate of 200 MHz is equivalent to 66M byte/sec, and a clock rate of 150 MHz is equivalent to 50M byte/sec.

DMA transfers are used to move data to and from internal memory. Access to the core is also facilitated through the parallel port register read/write functions. The RD, WR, and ALE (address latch enable) pins are the control pins for the parallel port.

## Timers

The ADSP-2126x has a total of four timers: a core timer able to generate periodic software interrupts, and three general-purpose timers that can generate periodic interrupts and be independently set to operate in one of three modes:

- Pulse waveform generation mode
- Pulse width count/capture mode
- External event watchdog mode

The core timer can be configured to use FLAG3 as a timer expired output signal, and each general-purpose timer has one bidirectional pin and four registers that implement its mode of operation: a 6-bit configuration register, a 32-bit count register,



a 32-bit period register, and a 32-bit pulse width register. A single control and status register enables or disables all three general-purpose timers independently.

## ROM-Based Security

The ADSP-2126x has a ROM security feature that provides hardware support for securing user software code by preventing unauthorized reading from the internal code when enabled. When using this feature, the DSP does not boot-load any external code, executing exclusively from internal SRAM/ROM. Additionally, the DSP is not freely accessible via the JTAG port. Instead, a unique 64-bit key, which must be scanned in through the JTAG or test access port, will be assigned to each customer. The device will ignore a wrong key. Emulation features and external boot modes are only available after the correct key is scanned.

## Program Booting

The internal memory of the ADSP-2126x boots at system power-up from an 8-bit EPROM via the parallel port, an SPI master, an SPI slave, or an internal boot. Booting is determined by the boot configuration (BOOT\_CFG1–0) pins.

## Phase-Locked Loop

The ADSP-2126x uses an on-chip phase-locked loop (PLL) to generate the internal clock for the core. On power-up, the CLK\_CFG1–0 pins are used to select ratios of 16:1, 8:1, and 3:1. After booting, numerous other ratios can be selected via software control. The ratios are made up of software configurable numerator values from 1 to 64 and software configurable divisor values of 2, 4, 8, and 16.

## Power Supplies

The ADSP-2126x has separate power supply connections for the internal ( $V_{DDINT}$ ), external ( $V_{DDEXT}$ ), and analog ( $A_{VDD}/A_{VSS}$ ) power supplies. The internal and analog supplies must meet the 1.2 V requirement. The external supply must meet the 3.3 V requirement. All external supply pins must be connected to the same power supply.

Note that the analog supply pin ( $A_{VDD}$ ) powers the ADSP-2126x's internal clock generator PLL. To produce a stable clock, it is recommended that PCB designs use an external filter circuit for the  $A_{VDD}$  pin. Place the filter components as close as possible to the  $A_{VDD}/A_{VSS}$  pins. For an example circuit, see [Figure 3](#). (A recommended ferrite chip is the muRata BLM18AG102SN1D). To reduce noise coupling, the PCB should use a parallel pair of power and ground planes for  $V_{DDINT}$  and GND. Use wide traces to connect the bypass capacitors to the analog power ( $A_{VDD}$ ) and ground ( $A_{VSS}$ ) pins. Note that the  $A_{VDD}$  and  $A_{VSS}$  pins specified in [Figure 3](#) are inputs to the processor and not the analog ground plane on the board—the  $A_{VSS}$  pin should connect directly to digital ground (GND) at the chip.

## TARGET BOARD JTAG EMULATOR CONNECTOR

Analog Devices DSP Tools product line of JTAG emulators uses the IEEE 1149.1 JTAG test access port of the ADSP-2126x processor to monitor and control the target board processor during

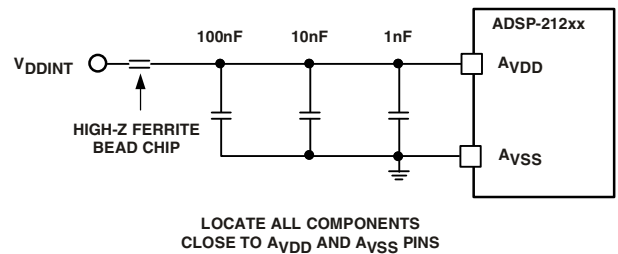

Figure 3. Analog Power Filter Circuit

emulation. Analog Devices DSP Tools product line of JTAG emulators provides emulation at full processor speed, allowing inspection and modification of memory, registers, and processor stacks. The processor's JTAG interface ensures that the emulator will not affect target system loading or timing.

For complete information on Analog Devices SHARC DSP Tools product line of JTAG emulator operation, see the appropriate emulator hardware user's guide.

## DEVELOPMENT TOOLS

The ADSP-2126x is supported by a complete automotive reference design and development board as well as by a complete home audio reference design board available from Analog Devices. These boards implement complete audio decoding and postprocessing algorithms that are factory programmed into the ROM space of the ADSP-2126x. SIMD optimized libraries consume less processing resources, which results in more available processing power for custom proprietary features.

The nonvolatile memory of the ADSP-2126x can be configured to contain a combination of Dolby Digital, Dolby Pro Logic, Dolby Pro Logic II, Dolby Pro Logic IIx, DTSES, DTS 96/24, and Neo:6. Multiple S/PDIF and analog I/Os are provided to maximize end system flexibility.

The ADSP-2126x is also supported with a complete set of CROSSCORE<sup>†</sup> software and hardware development tools, including Analog Devices emulators and VisualDSP++<sup>‡</sup> development environment. The same emulator hardware that supports other SHARC processors also fully emulates the ADSP-2126x.

The VisualDSP++ project management environment lets programmers develop and debug an application. This environment includes an easy to use assembler (which is based on an algebraic syntax), an archiver (librarian/library builder), a linker, a loader, a cycle-accurate instruction-level simulator, a C/C++ compiler, and a C/C++ runtime library that includes DSP and mathematical functions. A key point for these tools is C/C++ code efficiency. The compiler has been developed for efficient translation of C/C++ code to DSP assembly. The ADSP-2126x SHARC DSP has architectural features that improve the efficiency of compiled C/C++ code.

<sup>†</sup>CROSSCORE is a registered trademark of Analog Devices, Inc.

<sup>‡</sup>VisualDSP++ is a registered trademark of Analog Devices, Inc.

# ADSP-21261/ADSP-21262/ADSP-21266

The VisualDSP++ debugger has a number of important features. Data visualization is enhanced by a plotting package that offers a significant level of flexibility. This graphical representation of user data enables the programmer to quickly determine the performance of an algorithm. As algorithms grow in complexity, this capability can have increasing significance on the designer's development schedule, increasing productivity. Statistical profiling enables the programmer to nonintrusively poll the processor as it is running the program. This feature, unique to VisualDSP++, enables the software developer to passively gather important code execution metrics without interrupting the real-time characteristics of the program. Essentially, the developer can identify bottlenecks in software quickly and efficiently. By using the profiler, the programmer can focus on those areas in the program that impact performance and take corrective action.

Debugging both C/C++ and assembly programs with the VisualDSP++ debugger, programmers can

- View mixed C/C++ and assembly code (interleaved source and object information)
- Insert breakpoints
- Set conditional breakpoints on registers, memory, and stacks
- Perform linear or statistical profiling of program execution
- Fill, dump, and graphically plot the contents of memory
- Perform source level debugging
- Create custom debugger windows

The VisualDSP++ IDDE lets programmers define and manage DSP software development. Its dialog boxes and property pages let programmers configure and manage all of the SHARC development tools, including the color syntax highlighting in the VisualDSP++ editor. This capability permits programmers to

- Control how the development tools process inputs and generate outputs
- Maintain a one-to-one correspondence with the tools' command line switches

The VisualDSP++ Kernel (VDK) incorporates scheduling and resource management tailored specifically to address the memory and timing constraints of DSP programming. These capabilities enable engineers to develop code more effectively, eliminating the need to start from the very beginning when developing new application code. The VDK features include threads, critical and unscheduled regions, semaphores, events, and device flags. The VDK also supports priority-based, preemptive, cooperative, and time-sliced scheduling approaches. In addition, the VDK was designed to be scalable. If the application does not use a specific feature, the support code for that feature is excluded from the target system.

Because the VDK is a library, a developer can decide whether to use it or not. The VDK is integrated into the VisualDSP++ development environment, but can also be used via standard command line tools. When the VDK is used, the development environment assists the developer with many error-prone tasks

and assists in managing system resources, automating the generation of various VDK-based objects, and visualizing the system state when debugging an application that uses the VDK.

VisualDSP++ Component Software Engineering (VCSE) is Analog Devices' technology for creating, using, and reusing software components (independent modules of substantial functionality) to quickly and reliably assemble software applications. It also is used for downloading components from the Web, dropping them into the application, and publishing component archives from within VisualDSP++. VCSE supports component implementation in C/C++ or assembly language.

Use the expert linker to visually manipulate the placement of code and data on the embedded system. View memory utilization in a color-coded graphical form, easily move code and data to different areas of the DSP or external memory with a drag of the mouse, and examine run-time stack and heap usage. The expert linker is fully compatible with existing linker definition file (LDF), allowing the developer to move between the graphical and textual environments.

In addition to the software and hardware development tools available from Analog Devices, third parties provide a wide range of tools supporting the SHARC processor family. Hardware tools include SHARC processor PC plug-in cards. Third party software tools include DSP libraries, real-time operating systems, and block diagram design tools.

## EVALUATION KIT

Analog Devices offers a range of EZ-KIT Lite<sup>®†</sup> evaluation platforms to use as a cost-effective method to learn more about developing or prototyping applications with Analog Devices processors, platforms, and software tools. Each EZ-KIT Lite includes an evaluation board along with an evaluation suite of the VisualDSP++ development and debugging environment with the C/C++ compiler, assembler, and linker. Also included are sample application programs, power supply, and a USB cable. All evaluation versions of the software tools are limited for use only with the EZ-KIT Lite product.

The USB controller on the EZ-KIT Lite board connects the board to the USB port of the user's PC, enabling the VisualDSP++ evaluation suite to emulate the on-board processor in-circuit. This permits the customer to download, execute, and debug programs for the EZ-KIT Lite system. It also allows in-circuit programming of the on-board flash device to store user-specific boot code, enabling the board to run as a standalone unit, without being connected to the PC.

With a full version of VisualDSP++ installed (sold separately), engineers can develop software for the EZ-KIT Lite or any custom-defined system. Connecting one of Analog Devices JTAG emulators to the EZ-KIT Lite board enables high speed, nonintrusive emulation.

---

<sup>†</sup> EZ-KIT Lite is a registered trademark of Analog Devices, Inc.

**DESIGNING AN EMULATOR-COMPATIBLE DSP BOARD (TARGET)**

The Analog Devices family of emulators are tools that every DSP developer needs to test and debug hardware and software systems. Analog Devices has supplied an IEEE 1149.1 JTAG test access port (TAP) on each JTAG DSP. Nonintrusive in-circuit emulation is assured by the use of the processor's JTAG interface—the emulator does not affect target system loading or timing. The emulator uses the TAP to access the internal features of the DSP, allowing the developer to load code, set breakpoints, observe variables, observe memory, and examine registers. The DSP must be halted to send data and commands, but once an operation has been completed by the emulator, the DSP system is set running at full speed with no impact on system timing.

To use these emulators, the target board must include a header that connects the DSP's JTAG port to the emulator.

For details on target board design issues including mechanical layout, single processor connections, multiprocessor scan chains, signal buffering, signal termination, and emulator pod logic, see the *EE-68: Analog Devices JTAG Emulation Technical Reference* on the Analog Devices website ([www.analog.com](http://www.analog.com))—use site search on “EE-68.” This document is updated regularly to keep pace with improvements to emulator support.

**ADDITIONAL INFORMATION**

This data sheet provides a general overview of the ADSP-2126x architecture and functionality. For detailed information on the ADSP-2126x family core architecture and instruction set, refer to the *ADSP-2126x SHARC DSP Core Manual* and the *ADSP-21160 SHARC DSP Instruction Set Reference*.

# ADSP-21261/ADSP-21262/ADSP-21266

## PIN FUNCTION DESCRIPTIONS

The ADSP-2126x pin definitions are listed below. Inputs identified as synchronous (S) must meet timing requirements with respect to CLKIN (or with respect to TCK for TMS, TDI). Inputs identified as asynchronous (A) can be asserted asynchronously to CLKIN (or to TCK for TRST). Tie or pull unused inputs to  $V_{DDEXT}$  or GND, except for the following:

DAI\_Px, SPICLK, MISO, MOSI,  $\overline{EMU}$ ,  $\overline{TMS}$ ,  $\overline{TRST}$ , TDI and AD15–0 (NOTE: These pins have internal pull-up resistors.)

The following symbols appear in the Type column of Table 6: A = asynchronous, G = ground, I = input, O = output, P = power supply, S = synchronous, (A/D) = active drive, (O/D) = open-drain, and T = three-state.

Table 6. Pin Descriptions

Pin	Type	State During and After Reset	Function
AD15–0	I/O/T	Rev. 0.1 silicon—AD15–0 pins are driven low both during and after reset. Rev. 0.2 silicon—AD15–0 pins are three-stated and pulled high both during and after reset.	<b>Parallel Port Address/Data.</b> The parallel port and its corresponding DMA unit output addresses and data for peripherals on these multiplexed pins. The multiplex state is determined by the ALE pin. The parallel port can operate in either 8-bit or 16-bit mode. Each AD pin has a 22.5 k $\Omega$ internal pull-up resistor. See <a href="#">Address Data Modes on Page 15</a> for details of the AD pin operation. For 8-bit mode: ALE is automatically asserted whenever a change occurs in the upper 16 external address bits, A23–8; ALE is used in conjunction with an external latch to retain the values of the A23–8. For 16-bit mode: ALE is automatically asserted whenever a change occurs in the address bits, A15–0; ALE is used in conjunction with an external latch to retain the values of the A15–0. To use these pins as flags (FLAG15–0), set (= 1) Bit 20 of the SYSCTL register and disable the parallel port. See <a href="#">Table 7 on Page 15</a> for a list of how the AD15–0 pins map to the flag pins. When configured in the IDP_PDAP_CTL register, the IDP Channel 0 can use these pins for parallel input data.
$\overline{RD}$	O	Output only, driven high <sup>1</sup>	<b>Parallel Port Read Enable.</b> $\overline{RD}$ is asserted low whenever the DSP reads 8-bit or 16-bit data from an external memory device. When AD15–0 are flags, this pin remains deasserted.
$\overline{WR}$	O	Output only, driven high <sup>1</sup>	<b>Parallel Port Write Enable.</b> $\overline{WR}$ is asserted low whenever the DSP writes 8-bit or 16-bit data to an external memory device. When AD15–0 are flags, this pin remains deasserted.
ALE	O	Output only, driven low <sup>1</sup>	<b>Parallel Port Address Latch Enable.</b> ALE is asserted whenever the DSP drives a new address on the parallel port address pin. On reset, ALE is active high. However, it can be reconfigured using software to be active low. When AD15–0 are flags, this pin remains deasserted.
FLAG3–0	I/O/A	Three-state	<b>Flag Pins.</b> Each FLAG pin is configured via control bits as either an input or output. As an input, it can be tested as a condition. As an output, it can be used to signal external peripherals. These pins can be used as an SPI interface slave select output during SPI mastering. These pins are also multiplexed with the $\overline{IRQx}$ and the TIMEXP signals. In SPI master boot mode, FLAG0 is the slave select pin that must be connected to an SPI EPROM. FLAG0 is configured as a slave select during SPI master boot. When Bit 16 is set (= 1) in the SYSCTL register, FLAG0 is configured as $\overline{IRQ0}$ . When Bit 17 is set (= 1) in the SYSCTL register, FLAG1 is configured as $\overline{IRQ1}$ . When Bit 18 is set (= 1) in the SYSCTL register, FLAG2 is configured as $\overline{IRQ2}$ . When Bit 19 is set (= 1) in the SYSCTL register, FLAG3 is configured as TIMEXP, which indicates that the system timer has expired.
DAI_P20–1	I/O/T	Three-state with programmable pull-up	<b>Digital Audio Interface Pins.</b> These pins provide the physical interface to the SRU. The SRU configuration registers define the combination of on-chip peripheral inputs or outputs connected to the pin and to the pin's output enable. The configuration registers of these peripherals then determine the exact behavior of the pin. Any input or output signal present in the SRU can be routed to any of these pins. The SRU provides the connection from the serial ports, input data port, precision clock generators, and timers to the DAI_P20–1 pins. These pins have internal 22.5 k $\Omega$ pull up resistors which are enabled on reset. These pull-ups can be disabled in the DAI_PIN_PULLUP register.

**Table 6. Pin Descriptions (Continued)**

Pin	Type	State During and After Reset	Function
SPICLK	I/O	Three-state with pull-up enabled, driven high in SPI-master boot mode	<b>Serial Peripheral Interface Clock Signal.</b> Driven by the master, this signal controls the rate at which data is transferred. The master can transmit data at a variety of baud rates. SPICLK cycles once for each bit transmitted. SPICLK is a gated clock that is active during data transfers, only for the length of the transferred word. Slave devices ignore the serial clock if the slave select input is driven inactive (HIGH). SPICLK is used to shift out and shift in the data driven on the MISO and MOSI lines. The data is always shifted out on one clock edge and sampled on the opposite edge of the clock. Clock polarity and clock phase relative to data are programmable into the SPICTL control register and define the transfer format. SPICLK has a 22.5 k $\Omega$ internal pull-up resistor. If SPI master boot mode is selected, MOSI and SPICLK pins are driven during reset. These pins are not three-stated during reset in SPI master boot mode.
$\overline{\text{SPIDS}}$	I	Input only	<b>Serial Peripheral Interface Slave Device Select.</b> An active low signal used to select the DSP as an SPI slave device. This input signal behaves like a chip select, and is provided by the master device for the slave devices. In multimaster mode, the DSP's $\overline{\text{SPIDS}}$ signal can be driven by a slave device to signal to the DSP (as SPI master) that an error has occurred, as some other device is also trying to be the master device. If asserted low when the device is in master mode, it is considered a multimaster error. For a single master, multiple-slave configuration where flag pins are used, this pin must be tied or pulled high to $V_{\text{DDEXT}}$ on the master device. For ADSP-2126x to ADSP-2126x SPI interaction, any of the master ADSP-2126x's flag pins can be used to drive the $\overline{\text{SPIDS}}$ signal on the ADSP-2126x SPI slave device.
MOSI	I/O (O/D)	Three-state with pull-up enabled, driven low in SPI-master boot mode	<b>SPI Master Out Slave In.</b> If the ADSP-2126x is configured as a master, the MOSI pin becomes a data transmit (output) pin, transmitting output data. If the ADSP-2126x is configured as a slave, the MOSI pin becomes a data receive (input) pin, receiving input data. In an ADSP-2126x SPI interconnection, the data is shifted out from the MOSI output pin of the master and shifted into the MOSI input(s) of the slave(s). MOSI has a 22.5 k $\Omega$ internal pull-up resistor. If SPI master boot mode is selected, MOSI and SPICLK pins are driven during reset. These pins are not three-stated during reset in SPI master boot mode.
MISO	I/O (O/D)	Three-state with pull-up enabled	<b>SPI Master In Slave Out.</b> If the ADSP-2126x is configured as a master, the MISO pin becomes a data receive (input) pin, receiving input data. If the ADSP-2126x is configured as a slave, the MISO pin becomes a data transmit (output) pin, transmitting output data. In an ADSP-2126x SPI interconnection, the data is shifted out from the MISO output pin of the slave and shifted into the MISO input pin of the master. MISO has a 22.5 k $\Omega$ internal pull-up resistor. MISO can be configured as O/D by setting the OPD bit in the SPICTL register. <b>Note:</b> Only one slave is allowed to transmit data at any given time. To enable broadcast transmission to multiple SPI slaves, the DSP's MISO pin can be disabled by setting (=1) Bit 5 (DMISO) of the SPICTL register.
BOOT_CFG1-0	I	Input only	<b>Boot Configuration Select.</b> Selects the boot mode for the DSP. The BOOT_CFG pins must be valid before reset is asserted. See <a href="#">Table 8 on Page 15</a> for a description of the boot modes.
CLKIN	I	Input only	<b>Local Clock In.</b> Used in conjunction with XTAL. CLKIN is the ADSP-2126x clock input. It configures the ADSP-2126x to use either its internal clock generator or an external clock source. Connecting the necessary components to CLKIN and XTAL enables the internal clock generator. Connecting the external clock to CLKIN while leaving XTAL unconnected configures the ADSP-2126x to use the external clock source such as an external clock oscillator. The core is clocked either by the PLL output or this clock input depending on the CLK_CFG1-0 pin settings. CLKIN should not be halted, changed, or operated below the specified frequency.
XTAL	O	Output only <sup>2</sup>	<b>Crystal Oscillator Terminal.</b> Used in conjunction with CLKIN to drive an external crystal.

# ADSP-21261/ADSP-21262/ADSP-21266

Table 6. Pin Descriptions (Continued)

Pin	Type	State During and After Reset	Function
CLK_CFG1-0	I	Input only	<b>Core/CLKIN Ratio Control.</b> These pins set the start up clock frequency. See <a href="#">Table 9</a> for a description of the clock configuration modes. Note that the operating frequency can be changed by programming the PLL multiplier and divider in the PMCTL register at any time after the core comes out of reset.
$\overline{\text{RESETOUT}}$ / CLKOUT	O	Output only	<b>Reset Out/Local Clock Out.</b> Drives out the core reset signal to an external device. CLKOUT can also be configured as a reset out pin ( $\overline{\text{RESETOUT}}$ ). The functionality can be switched between the PLL output clock and reset out by setting Bit 12 of the PMCTL register. The default is reset out.
$\overline{\text{RESET}}$	I/A	Input only	<b>Processor Reset.</b> Resets the ADSP-2126x to a known state. Upon deassertion, there is a 4096 CLKIN cycle latency for the PLL to lock. After this time, the core begins program execution from the hardware reset vector address. The $\overline{\text{RESET}}$ input must be asserted (low) at power-up.
TCK	I	Input only <sup>3</sup>	<b>Test Clock (JTAG).</b> Provides a clock for JTAG boundary scan. TCK must be asserted (pulsed low) after power-up or held low for proper operation of the ADSP-2126x.
TMS	I/S	Three-state with pull-up enabled	<b>Test Mode Select (JTAG).</b> Used to control the test state machine. TMS has a 22.5 k $\Omega$ internal pull-up resistor.
TDI	I/S	Three-state with pull-up enabled	<b>Test Data Input (JTAG).</b> Provides serial data for the boundary scan logic. TDI has a 22.5 k $\Omega$ internal pull-up resistor.
TDO	O	Three-state <sup>4</sup>	<b>Test Data Output (JTAG).</b> Serial scan output of the boundary scan path.
$\overline{\text{TRST}}$	I/A	Three-state with pull-up enabled	<b>Test Reset (JTAG).</b> Resets the test state machine. $\overline{\text{TRST}}$ must be asserted (pulsed low) after power-up or held low for proper operation of the ADSP-2126x. $\overline{\text{TRST}}$ has a 22.5 k $\Omega$ internal pull-up resistor.
$\overline{\text{EMU}}$	O (O/D)	Three-state with pull-up enabled	<b>Emulation Status.</b> Must be connected to the ADSP-2126x Analog Devices DSP Tools product line of JTAG emulators target board connector only. $\overline{\text{EMU}}$ has a 22.5 k $\Omega$ internal pull-up resistor.
V <sub>DDINT</sub>	P		<b>Core Power Supply.</b> Nominally +1.2 V dc and supplies the DSP's core processor (13 pins on the BGA package, 32 pins on the LQFP package).
V <sub>DDEXT</sub>	P		<b>I/O Power Supply.</b> Nominally +3.3 V dc (6 pins on the BGA package, 10 pins on the LQFP package).
A <sub>VDD</sub>	P		<b>Analog Power Supply.</b> Nominally +1.2 V dc and supplies the DSP's internal PLL (clock generator). This pin has the same specifications as V <sub>DDINT</sub> , except that added filtering circuitry is required. <a href="#">For more information, see Power Supplies on Page 9.</a>
A <sub>VSS</sub>	G		<b>Analog Power Supply Return.</b>
GND	G		<b>Power Supply Return.</b> (54 pins on the BGA package, 39 pins on the LQFP package).

<sup>1</sup>  $\overline{\text{RD}}$ ,  $\overline{\text{WR}}$ , and ALE are continuously driven by the DSP and will not be three-stated.

<sup>2</sup> Output only is a three-state driver with its output path always enabled.

<sup>3</sup> Input only is a three-state driver, with both output path and pull-up disabled.

<sup>4</sup> Three-state is a three-state driver, with pull-up disabled.

## ADDRESS DATA PINS AS FLAGS

To use these pins as flags (FLAG15–0), set (= 1) Bit 20 of the SYSCCTL register and disable the parallel port.

**Table 7. AD15–0 to FLAG Pin Mapping**

AD Pin	Flag Pin	AD Pin	Flag Pin
AD0	FLAG8	AD8	FLAG0
AD1	FLAG9	AD9	FLAG1
AD2	FLAG10	AD10	FLAG2
AD3	FLAG11	AD11	FLAG3
AD4	FLAG12	AD12	FLAG4
AD5	FLAG13	AD13	FLAG5
AD6	FLAG14	AD14	FLAG6
AD7	FLAG15	AD15	FLAG7

## Boot Modes

**Table 8. Boot Mode Selection**

BOOT_CFG1–0	Booting Mode
00	SPI Slave Boot
01	SPI Master Boot
10	Parallel Port Boot via EPROM
11	Reserved

## CORE INSTRUCTION RATE TO CLKIN RATIO MODES

**Table 9. Core Instruction Rate/CLKIN Ratio Selection**

CLK_CFG1–0	Core to CLKIN Ratio
00	3:1
01	16:1
10	8:1
11	Reserved

## ADDRESS DATA MODES

Table 10 shows the functionality of the AD pins for 8-bit and 16-bit transfers to the parallel port. For 8-bit data transfers, ALE latches address bits A23–A8 when asserted, followed by address bits A7–A0 and data bits D7–D0 when deasserted. For 16-bit data transfers, ALE latches address bits A15–A0 when asserted, followed by data bits D15–D0 when deasserted.

**Table 10. Address/Data Mode Selection**

EP Data Mode	ALE	AD7–0 Function	AD15–8 Function
8-bit	Asserted	A15–8	A23–16
8-bit	Deasserted	D7–0	A7–0
16-bit	Asserted	A7–0	A15–8
16-bit	Deasserted	D7–0	D15–8

# ADSP-21261/ADSP-21262/ADSP-21266

## PRODUCT SPECIFICATIONS

### OPERATING CONDITIONS

Parameter <sup>1</sup>		Min	Max	Unit
V <sub>DDINT</sub>	Internal (Core) Supply Voltage	1.14	1.26	V
A <sub>VDD</sub>	Analog (PLL) Supply Voltage	1.14	1.26	V
V <sub>DDEXT</sub>	External (I/O) Supply Voltage	3.13	3.47	V
V <sub>IH</sub>	High Level Input Voltage <sup>2</sup> @ V <sub>DDEXT</sub> = Max	2.0	V <sub>DDEXT</sub> + 0.5	V
V <sub>IL</sub>	Low Level Input Voltage <sup>2</sup> @ V <sub>DDEXT</sub> = Min	-0.5	+0.8	V
V <sub>IH_CLKIN</sub>	High Level Input Voltage <sup>3</sup> @ V <sub>DDEXT</sub> = Max	1.74	V <sub>DDEXT</sub> + 0.5	V
V <sub>IL_CLKIN</sub>	Low Level Input Voltage @ V <sub>DDEXT</sub> = Min	-0.5	+1.19	V
T <sub>AMB</sub> K Grade	Ambient Operating Temperature <sup>4, 5</sup>	0	+70	°C

<sup>1</sup> Specifications subject to change without notice.

<sup>2</sup> Applies to input and bidirectional pins: AD15-0, FLAG3-0, DAI\_Px, SPICLK, MOSI, MISO,  $\overline{\text{SPIDS}}$ , BOOT\_CFGx, CLK\_CFGx,  $\overline{\text{RESET}}$ , TCK, TMS, TDI,  $\overline{\text{TRST}}$ .

<sup>3</sup> Applies to input pin CLKIN.

<sup>4</sup> See [Thermal Characteristics on Page 40](#) for information on thermal specifications.

<sup>5</sup> See Engineer-to-Engineer Note (No. EE-216) for further information.

### ELECTRICAL CHARACTERISTICS

Parameter <sup>1</sup>	Test Conditions	Min	Max	Unit
V <sub>OH</sub>	High Level Output Voltage <sup>2</sup>	2.4		V
V <sub>OL</sub>	Low Level Output Voltage <sup>2</sup>		0.4	V
I <sub>IH</sub>	High Level Input Current <sup>4, 5</sup>		10	μA
I <sub>IL</sub>	Low Level Input Current <sup>4</sup>		10	μA
I <sub>ILPU</sub>	Low Level Input Current Pull-Up <sup>5</sup>		200	μA
I <sub>OZH</sub>	Three-State Leakage Current <sup>6, 7, 8</sup>		10	μA
I <sub>OZL</sub>	Three-State Leakage Current <sup>6</sup>		10	μA
I <sub>OZLPU</sub>	Three-State Leakage Current Pull-Up <sup>7</sup>		200	μA
I <sub>DD-INTYP</sub>	Supply Current (Internal) <sup>9, 10, 11</sup>	t <sub>CCLK</sub> = 5.0 ns, V <sub>DDINT</sub> = 1.2 V, T <sub>AMB</sub> = +25°C	500	mA
I <sub>AVDD</sub>	Supply Current (Analog) <sup>11</sup>	A <sub>VDD</sub> = Max	10	mA
C <sub>IN</sub>	Input Capacitance <sup>12, 13</sup>	f <sub>IN</sub> = 1 MHz, T <sub>CASE</sub> = 25°C, V <sub>IN</sub> = 1.2 V	4.7	pF

<sup>1</sup> Specifications subject to change without notice.

<sup>2</sup> Applies to output and bidirectional pins: AD15-0,  $\overline{\text{RD}}$ ,  $\overline{\text{WR}}$ , ALE, FLAG3-0, DAI\_Px, SPICLK, MOSI, MISO,  $\overline{\text{EMU}}$ , TDO, CLKOUT, XTAL.

<sup>3</sup> See [Output Drive Currents on Page 39](#) for typical drive current capabilities.

<sup>4</sup> Applies to input pins:  $\overline{\text{SPIDS}}$ , BOOT\_CFGx, CLK\_CFGx, TCK,  $\overline{\text{RESET}}$ , CLKIN.

<sup>5</sup> Applies to input pins with 22.5 kΩ internal pull-ups:  $\overline{\text{TRST}}$ , TMS, TDI.

<sup>6</sup> Applies to three-statable pins: FLAG3-0.

<sup>7</sup> Applies to three-statable pins with 22.5 kΩ pull-ups: AD15-0, DAI\_Px, SPICLK, MISO, MOSI.

<sup>8</sup> Applies to open-drain output pins:  $\overline{\text{EMU}}$ , MISO, MOSI.

<sup>9</sup> Typical internal current data reflects nominal operating conditions.

<sup>10</sup> See Engineer-to-Engineer Note (EE-216) for further information.

<sup>11</sup> Characterized, but not tested.

<sup>12</sup> Applies to all signal pins.

<sup>13</sup> Guaranteed, but not tested.



## PACKAGE INFORMATION

The information presented in [Figure 4](#) provides details about the package branding for the ADSP-21266 processors. For a complete listing of product availability, see [Ordering Guide on Page 47](#).



Figure 4. Typical Package Brand

Table 11. Package Brand Information

Brand Key	Field Description
t	Temperature Range
pp	Package Type
Z	RoHS Compliant Option (optional)
cc	See Ordering Guide
vvvvvv.x	Assembly Lot Code
n.n	Silicon Revision
#	RoHS Compliant Designation
yyww	Date Code

## ESD CAUTION



**ESD (electrostatic discharge) sensitive device.** Charged devices and circuit boards can discharge without detection. Although this product features patented or proprietary protection circuitry, damage may occur on devices subjected to high energy ESD. Therefore, proper ESD precautions should be taken to avoid performance degradation or loss of functionality.

## MAXIMUM POWER DISSIPATION

See *Estimating Power for the ADSP-21262 SHARC Processors (EE-216)* for detailed thermal and power information regarding maximum power dissipation. For information on package thermal specifications, see [Thermal Characteristics on Page 40](#).

## ABSOLUTE MAXIMUM RATINGS

Stresses greater than those listed in [Table 12](#) may cause permanent damage to the device. These are stress ratings only; functional operation of the device at these or any other conditions greater than those indicated in the operational sections of this specification is not implied. Exposure to absolute maximum rating conditions for extended periods may affect device reliability.

Table 12. Absolute Maximum Ratings

Parameter	Rating
Internal (Core) Supply Voltage ( $V_{DDINT}$ )	-0.3 V to +1.4 V
Analog (PLL) Supply Voltage ( $A_{VDD}$ )	-0.3 V to +1.4 V
External (I/O) Supply Voltage ( $V_{DDEXT}$ )	-0.3 V to +3.8 V
Input Voltage -0.5 V to $V_{DDEXT}$	+0.5 V
Output Voltage Swing -0.5 V to $V_{DDEXT}$	+0.5 V
Load Capacitance	200 pF
Storage Temperature Range	-65°C to +150°C
Junction Temperature Under Bias	125°C

## TIMING SPECIFICATIONS

The ADSP-2126x's internal clock (a multiple of CLKIN) provides the clock signal for timing internal memory, processor core, serial ports, and parallel port (as required for read/write strobes in asynchronous access mode). During reset, program the ratio between the DSP's internal clock frequency and external (CLKIN) clock frequency with the CLK\_CFG1-0 pins. To determine switching frequencies for the serial ports, divide down the internal clock, using the programmable divider control of each port (DIVx for the serial ports).

The ADSP-2126x's internal clock switches at higher frequencies than the system input clock (CLKIN). To generate the internal clock, the DSP uses an internal phase-locked loop (PLL). This PLL-based clocking minimizes the skew between the system clock (CLKIN) signal and the DSP's internal clock (the clock source for the parallel port logic and I/O pads).

Note the definitions of various clock periods that are a function of CLKIN and the appropriate ratio control shown in [Table 13](#) and [Table 14](#).

In [Table 13](#), CCLK is defined as

$$f_{CCLK} = (2 \times PLLM \times f_{INPUT}) \div (2 \times PLLN)$$

where:

$f_{CCLK}$  = CCLK frequency

$PLLM$  = Multiplier value programmed

$PLLN$  = Divider value programmed.

Table 13. CLKOUT and CCLK Clock Generation Operation

Timing Requirements	Description	Calculation
CLKIN	Input Clock	$1/t_{CK}$
CCLK	Core Clock	Variable, see equation

Note the definitions of various clock periods shown in [Table 14](#) which are a function of CLKIN and the appropriate ratio control shown in [Table 13](#).

# ADSP-21261/ADSP-21262/ADSP-21266

**Table 14. Clock Periods**

Timing Requirements	Description <sup>1</sup>
$t_{CK}$	CLKIN Clock Period
$t_{CCLK}$	(Processor) Core Clock Period
$t_{MCLK}$	Internal memory clock = $1/2 t_{CCLK}$
$t_{SCLK}$	Serial Port Clock Period = $(t_{CCLK}) \times SR$
$t_{SPICLK}$	SPI Clock Period = $(t_{CCLK}) \times SPIR$

<sup>1</sup> where:  
 SR = serial port-to-core clock ratio (wide range, determined by SPORT CLKDIV)  
 SPIR = SPI-to-core clock ratio (wide range, determined by SPIBAUD register)  
 SCLK = serial port clock  
 SPICLK = SPI clock

Figure 5 shows core to CLKIN relationships with external oscillator or crystal. The shaded divider/multiplier blocks denote where clock ratios can be set through hardware or software using the power management control register (PMCTL). For more information, see the *ADSP-2126x SHARC Processor Peripherals Reference* and *Managing the Core PLL on Third-Generation SHARC Processors (EE-290)*.

Use the exact timing information given. Do not attempt to derive parameters from the addition or subtraction of others. While addition or subtraction would yield meaningful results for an individual device, the values given in this data sheet reflect statistical variations and worst cases. Consequently, it is not meaningful to add parameters to derive longer times.

See Figure 30 on Page 39 under Test Conditions for voltage reference levels.

Note that in the user application, the PLL multiplier value should be selected in such a way that the VCO frequency never exceeds  $f_{VCO}$  specified in Table 16. The VCO frequency is calculated as follows:

$$f_{VCO} = 2 \times PLLM \times f_{INPUT}$$

where:

$f_{VCO}$  is the VCO frequency.

$PLLM$  is the multiplier value programmed.

$f_{INPUT}$  is the input frequency to the PLL.

$f_{INPUT} = CLKIN$  when the input divider is disabled and

$f_{INPUT} = CLKIN \div 2$  when the input divider is enabled.

Timing requirements apply to signals that are controlled by circuitry external to the processor, such as the data input for a read operation. Timing requirements guarantee that the processor operates correctly with other devices.

Switching characteristics specify how the processor changes its signals. Circuitry external to the processor must be designed for compatibility with these signal characteristics. Switching characteristics describe what the processor will do in a given circumstance. Use switching characteristics to ensure that any timing requirement of a device connected to the processor (such as memory) is satisfied.

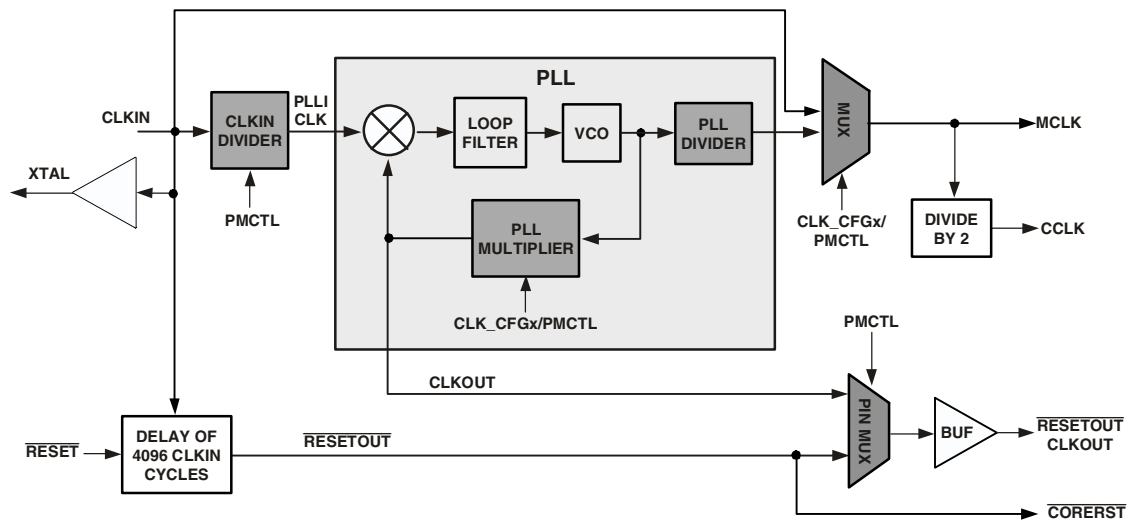

Figure 5. Core Clock and System Clock Relationship to CLKIN

## Power-Up Sequencing

The timing requirements for DSP startup are given in [Table 15](#) and [Figure 6](#).

**Table 15. Power-Up Sequencing (DSP Startup)**

Parameter		Min	Max	Unit
<i>Timing Requirements</i>				
$t_{RSTVDD}$	$\overline{RESET}$ Low Before $V_{DDINT}/V_{DDEXT}$ On	0		ns
$t_{IVDDEVDD}$	$V_{DDINT}$ On Before $V_{DDEXT}$	-50	+200	ms
$t_{CLKVDD}$	CLKIN Valid After $V_{DDINT}/V_{DDEXT}$ Valid <sup>1</sup>	0	200	ms
$t_{CLKRST}$	CLKIN Valid Before $\overline{RESET}$ Deasserted	$10^2$		$\mu$ s
$t_{PLLST}$	PLL Control Setup Before $\overline{RESET}$ Deasserted	$20^3$		$\mu$ s
<i>Switching Characteristics</i>				
$t_{CORERST}$	DSP Core Reset Deasserted After $\overline{RESET}$ Deasserted	$4096 \times t_{CK}$ <sup>4, 5</sup>		

<sup>1</sup> Valid  $V_{DDINT}/V_{DDEXT}$  assumes that the supplies are fully ramped to their 1.2 V and 3.3 V rails. Voltage ramp rates can vary from microseconds to hundreds of milliseconds depending on the design of the power supply subsystem.

<sup>2</sup> Assumes a stable CLKIN signal, after meeting worst-case startup timing of crystal oscillators. Refer to the crystal oscillator manufacturer's data sheet for startup time. Assume a 25 ms maximum oscillator startup time if using the XTAL pin and internal oscillator circuit in conjunction with an external crystal.

<sup>3</sup> Based on CLKIN cycles.

<sup>4</sup> Applies after the power-up sequence is complete. Subsequent resets require a minimum of four CLKIN cycles for  $\overline{RESET}$  to be held low in order to properly initialize and propagate default states at all I/O pins.

<sup>5</sup> The 4096 cycle count depends on  $t_{SRST}$  specification in [Table 17](#). If setup time is not met, one additional CLKIN cycle can be added to the core reset time, resulting in 4097 cycles maximum.

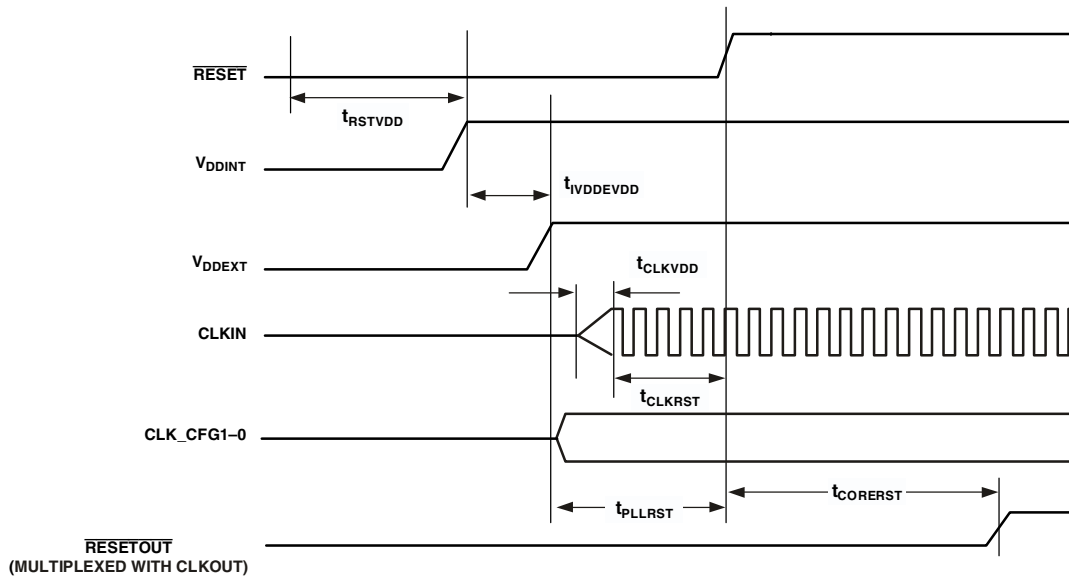

Figure 6. Power-Up Sequencing

# ADSP-21261/ADSP-21262/ADSP-21266

## Clock Input

See [Table 16](#) and [Figure 7](#).

**Table 16. Clock Input**

Parameter	150 MHz <sup>1</sup>		200 MHz <sup>2</sup>		Unit
	Min	Max	Min	Max	
<i>Timing Requirements</i>					
t <sub>CK</sub>	CLKIN Period		15 <sup>3</sup>	160 <sup>4</sup>	ns
t <sub>CKL</sub>	CLKIN Width Low		6 <sup>3</sup>	80 <sup>4</sup>	ns
t <sub>CKH</sub>	CLKIN Width High		6 <sup>3</sup>	80 <sup>4</sup>	ns
t <sub>CKRF</sub>	CLKIN Rise/Fall (0.4 V to 2.0 V)			3	ns
f <sub>VCO</sub> <sup>5</sup>	VCO Frequency		200	800	MHz
t <sub>CCLK</sub>	CCLK Period <sup>6</sup>		5	10	ns

<sup>1</sup> Applies to all 150 MHz models. See [Ordering Guide on Page 47](#).

<sup>2</sup> Applies to all 200 MHz models. See [Ordering Guide on Page 47](#).

<sup>3</sup> Applies only for CLK\_CFG1-0 = 00 and default values for PLL control bits in PMCTL.

<sup>4</sup> Applies only for CLK\_CFG1-0 = 01 and default values for PLL control bits in PMCTL.

<sup>5</sup> See [Figure 5 on Page 18](#) for VCO diagram.

<sup>6</sup> Any changes to PLL control bits in the PMCTL register must meet core clock timing specification t<sub>CCLK</sub>.

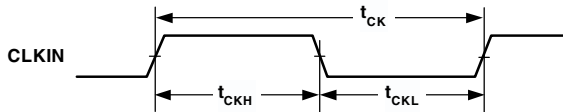
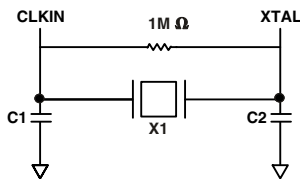

Figure 7. Clock Input

## Clock Signals

The ADSP-2126x can use an external clock or a crystal. See CLKIN pin description. The programmer can configure the ADSP-2126x to use its internal clock generator by connecting the necessary components to CLKIN and XTAL. [Figure 8](#) shows the component connections used for a crystal operating in fundamental mode. Note that the 200 MHz clock rate is achieved using a 12.5 MHz crystal and a PLL multiplier ratio 16:1 (CCLK:CLKIN).



NOTE: C1 AND C2 ARE SPECIFIC TO CRYSTAL SPECIFIED FOR X1. CONTACT CRYSTAL MANUFACTURER FOR DETAILS. CRYSTAL SELECTION MUST COMPLY WITH CLKCFG1-0 = 10 OR = 01.

Figure 8. 150 MHz or 200 MHz Operation with a 12.5 MHz Fundamental Mode Crystal

## Reset

See [Table 17](#) and [Figure 9](#).

**Table 17. Reset**

Parameter	Min	Max	Unit
<i>Timing Requirements</i>			
$t_{WRST}$ $\overline{RESET}$ Pulse Width Low <sup>1</sup>	$4 \times t_{CK}$		ns
$t_{SRST}$ $\overline{RESET}$ Setup Before CLKIN Low	8		ns

<sup>1</sup>Applies after the power-up sequence is complete. At power-up, the processor's internal phase-locked loop requires no more than 100  $\mu$ s while  $\overline{RESET}$  is low, assuming stable VDD and CLKIN (not including start-up time of external clock oscillator).

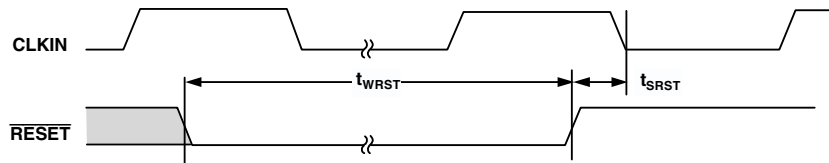

Figure 9. Reset

## Interrupts

The timing specification in [Table 18](#) and [Figure 10](#) applies to the FLAG0, FLAG1, and FLAG2 pins when they are configured as  $\overline{IRQ0}$ ,  $\overline{IRQ1}$ , and  $\overline{IRQ2}$  interrupts. Also applies to DAI\_P20-1 pins when configured as interrupts.

**Table 18. Interrupts**

Parameter	Min	Max	Unit
<i>Timing Requirements</i>			
$t_{IPW}$ $\overline{IRQx}$ Pulse Width	$2 t_{CCLK} + 2$		ns

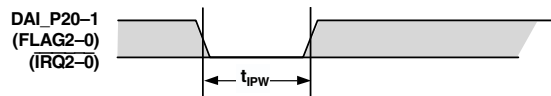

Figure 10. Interrupts

# ADSP-21261/ADSP-21262/ADSP-21266

## Core Timer

The timing specification in [Table 19](#) and [Figure 11](#) applies to FLAG3 when it is configured as the core timer (CTIMER).

**Table 19. Core Timer**

Parameter	Min	Max	Unit
<i>Switching Characteristics</i>			
$t_{WCTIM}$ CTIMER Pulse Width	$4 \times t_{CCLK} - 1$		ns

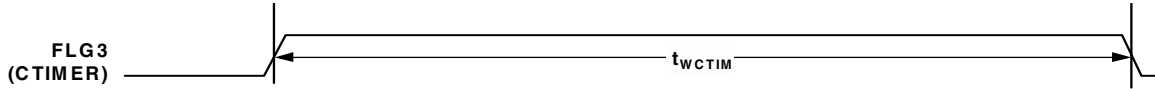

Figure 11. Core Timer

## Timer PWM\_OUT Cycle Timing

The timing specification in [Table 20](#) and [Figure 12](#) applies to Timer in PWM\_OUT (pulse-width modulation) mode. Timer signals are routed to the DAI\_P20-1 pins through the SRU. Therefore, the timing specifications provided below are valid at the DAI\_P20-1 pins.

**Table 20. Timer PWM\_OUT Timing**

Parameter	Min	Max	Unit
<i>Switching Characteristics</i>			
$t_{PWMO}$ Timer Pulse Width Output	$2 \times t_{CCLK} - 1$	$2(2^{31} - 1) \times t_{CCLK}$	ns

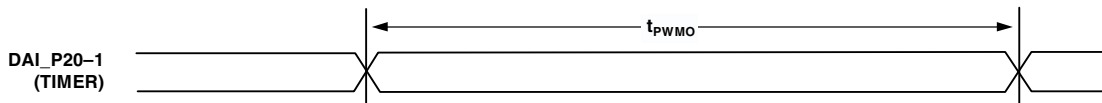

Figure 12. Timer PWM\_OUT Timing

**Timer WDT<sub>H</sub>\_CAP Timing**

The timing specification in Table 21 and Figure 13 applies to Timer in WDT<sub>H</sub>\_CAP (pulse width count and capture) mode. Timer signals are routed to the DAI\_P20-1 pins through the SRU. Therefore, the timing specifications provided below are valid at the DAI\_P20-1 pins.

**Table 21. Timer Width Capture Timing**

Parameter	Min	Max	Unit
<i>Timing Requirements</i>			
$t_{PWI}$ Timer Pulse Width	$2 \times t_{CCLK}$	$2(2^{31} - 1) \times t_{CCLK}$	ns

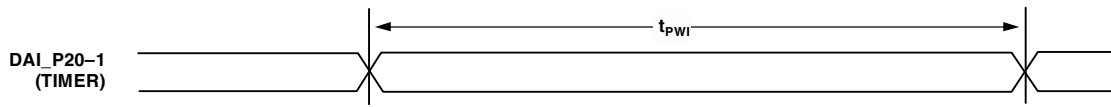

Figure 13. Timer Width Capture Timing

# ADSP-21261/ADSP-21262/ADSP-21266

## DAI Pin-to-Pin Direct Routing

See [Table 22](#) and [Figure 14](#) for direct pin connections only (for example, DAI\_PB01\_I to DAI\_PB02\_O).

Table 22. DAI Pin-to-Pin Routing

Parameter	Min	Max	Unit
<i>Timing Requirements</i>			
$t_{DPIO}$ Delay DAI Pin Input Valid to DAI Output Valid	1.5	10	ns

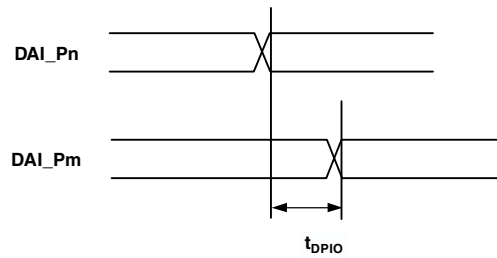

Figure 14. DAI Pin-to-Pin Direct Routing



## Precision Clock Generator (Direct Pin Routing)

The timing in Table 23 and Figure 15 is valid only when the SRU is configured such that the precision clock generator (PCG) takes its inputs directly from the DAI pins (via pin buffers) and sends its outputs directly to the DAI pins. For the other

cases where the PCG's inputs and outputs are not directly routed to/from DAI pins (via pin buffers), there is no timing data available. All timing parameters and switching characteristics apply to external DAI pins (DAI\_P07–DAI\_P20).

**Table 23. Precision Clock Generator (Direct Pin Routing)**

Parameter		Min	Max	Unit
<i>Timing Requirements</i>				
$t_{PCGIW}$	Input Clock Pulse Width	20		ns
$t_{STRIG}$	PCG Trigger Setup Before Falling Edge of PCG Input Clock	2		ns
$t_{HTRIG}$	PCG Trigger Hold After Falling Edge of PCG Input Clock	2		ns
<i>Switching Characteristics</i>				
$t_{DPCGIO}$	PCG Output Clock and Frame Sync Active Edge Delay After PCG Input Clock Falling Edge	2.5	10	ns
$t_{DTRIG}$	PCG Output Clock and Frame Sync Delay After PCG Trigger	$2.5 + 2.5 \times t_{PCGOW}$	$10 + 2.5 \times t_{PCGOW}$	ns
$t_{PCGOW}$	Output Clock Pulse Width	40		ns

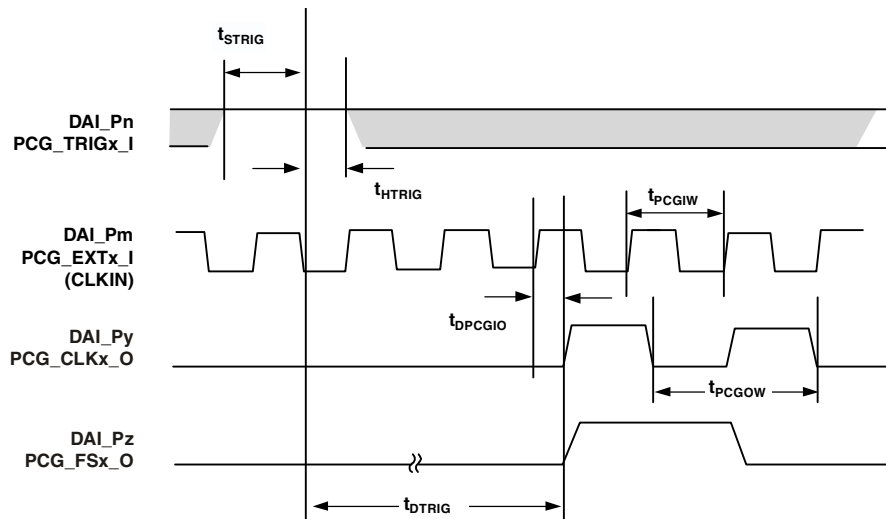

Figure 15. Precision Clock Generator (Direct Pin Routing)

# ADSP-21261/ADSP-21262/ADSP-21266

## Flags

The timing specifications in [Table 24](#) and [Figure 16](#) apply to the FLAG3-0 and DAI\_P20-1 pins, the parallel port, and the serial peripheral interface. See [Table 6 on Page 12](#) for more information on flag use.

**Table 24. Flags**

Parameter	Min	Max	Unit
<i>Timing Requirements</i>			
$t_{FIPW}$ FLAG3-0 IN Pulse Width	$2 \times t_{CLK} + 3$		ns
<i>Switching Characteristics</i>			
$t_{FOPW}$ FLAG3-0 OUT Pulse Width	$2 \times t_{CLK} - 1$		ns

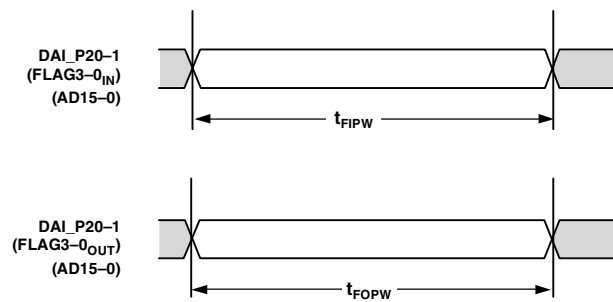

Figure 16. Flags

## Memory Read—Parallel Port

The specifications in Table 25, Table 26, Figure 17, and Figure 18 are for asynchronous interfacing to memories (and memory-mapped peripherals) when the ADSP-2126x is accessing external memory space.

**Table 25. 8-Bit Memory Read Cycle**

Parameter		Min	Max	Unit
<i>Timing Requirements</i>				
$t_{DRS}$	Address/Data 7–0 Setup Before $\overline{RD}$ High	3.3		ns
$t_{DRH}$	Address/Data 7–0 Hold After $\overline{RD}$ High	0		ns
$t_{DAD}$	Address 15–8 to Data Valid		$D + 0.5 \times t_{CCLK} - 3.5$	ns
<i>Switching Characteristics</i>				
$t_{ALEW}$	ALE Pulse Width	$2 \times t_{CCLK} - 2$		ns
$t_{ALERW}$	ALE Deasserted to Read/Write Asserted	$1 \times t_{CCLK} - 0.5$		ns
$t_{ADAS}^1$	Address/Data 15–0 Setup Before ALE Deasserted	$2.5 \times t_{CCLK} - 2.0$		ns
$t_{ADAH}^1$	Address/Data 15–0 Hold After ALE Deasserted	$0.5 \times t_{CCLK} - 0.8$		ns
$t_{ALEHZ}^1$	ALE Deasserted to Address/Data 7–0 in High-Z	$0.5 \times t_{CCLK} - 0.8$	$0.5 \times t_{CCLK} + 2.0$	ns
$t_{RW}$	$\overline{RD}$ Pulse Width	$D - 2$		ns
$t_{ADRH}$	Address/Data 15–8 Hold After $\overline{RD}$ High	$0.5 \times t_{CCLK} - 1 + H$		ns

$D = (\text{The value set by the PPDUR Bits (5–1) in the PPCTL register}) \times t_{CCLK}$   
 $H = t_{CCLK}$  (if a hold cycle is specified, else  $H = 0$ )

<sup>1</sup> On reset, ALE is an active high cycle. However, it can be reconfigured by software to be active low.

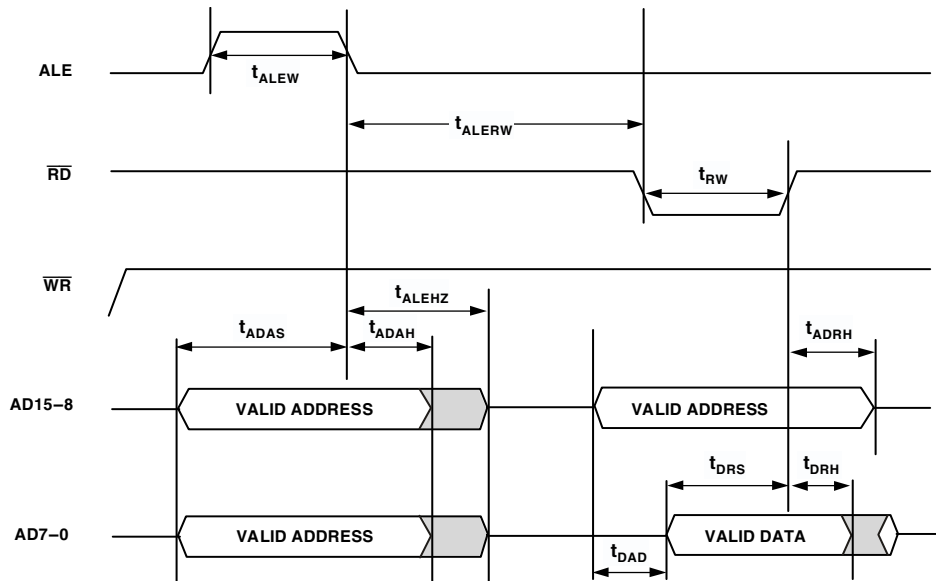

Figure 17. 8-Bit Memory Read Cycle

# ADSP-21261/ADSP-21262/ADSP-21266

Table 26. 16-Bit Memory Read Cycle

Parameter		Min	Max	Unit
<i>Timing Requirements</i>				
$t_{DRS}$	Address/Data 15-0 Setup Before $\overline{RD}$ high	3.3		ns
$t_{DRH}$	Address/Data 15-0 Hold After $\overline{RD}$ high	0		ns
<i>Switching Characteristics</i>				
$t_{ALEW}$	ALE Pulse Width	$2 \times t_{CCLK} - 2$		ns
$t_{ALERW}$	ALE Deasserted to Read/Write Asserted	$1 \times t_{CCLK} - 0.5$		ns
$t_{ADAS}^1$	Address/Data 15-0 Setup Before ALE Deasserted	$2.5 \times t_{CCLK} - 2.0$		ns
$t_{ADAH}^1$	Address/Data 15-0 Hold After ALE Deasserted	$0.5 \times t_{CCLK} - 0.8$		ns
$t_{ALEHZ}^1$	ALE Deasserted to Address/Data 15-0 in High-Z	$0.5 \times t_{CCLK} - 0.8$	$0.5 \times t_{CCLK} + 2.0$	ns
$t_{RW}$	$\overline{RD}$ Pulse Width	$D - 2$		ns

$D = (\text{The value set by the PPDUR Bits (5-1) in the PPCTL register}) \times t_{CCLK}$

$H = t_{CCLK}$  (if a hold cycle is specified, else  $H = 0$ )

<sup>1</sup> On reset, ALE is an active high cycle. However, it can be reconfigured by software to be active low.

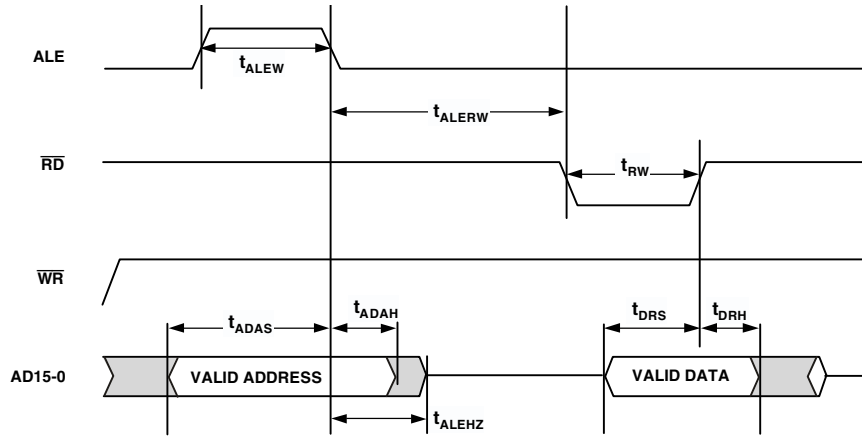

Figure 18. 16-Bit Memory Read Cycle

## Memory Write—Parallel Port

Use the specifications in Table 27, Table 28, Figure 19, and Figure 20 for asynchronous interfacing to memories (and memory-mapped peripherals) when the ADSP-2126x is accessing external memory space.

**Table 27. 8-Bit Memory Write Cycle**

Parameter	Min	Max	Unit
<i>Switching Characteristics</i>			
$t_{ALEW}$	ALE Pulse Width		ns
$t_{ALERW}$	ALE Deasserted to Read/Write Asserted		ns
$t_{ADAS}^1$	Address/Data 15–0 Setup Before ALE Deasserted		ns
$t_{ADAH}^1$	Address/Data 15–0 Hold After ALE Deasserted		ns
$t_{WW}$	$\overline{WR}$ Pulse Width		ns
$t_{ADWL}$	Address/Data 15–8 to $\overline{WR}$ Low		ns
$t_{ADWH}$	Address/Data 15–8 Hold After $\overline{WR}$ High		ns
$t_{ALEHZ}$	ALE Deasserted to Address/Data 15–0 in High-Z		ns
$t_{DWS}$	Address/Data 7–0 Setup Before $\overline{WR}$ High		ns
$t_{DWH}$	Address/Data 7–0 Hold After $\overline{WR}$ High		ns
$t_{DAWH}$	Address/Data to $\overline{WR}$ High		ns

D = (The value set by the PPDUR Bits (5–1) in the PPCTL register)  $\times t_{CCLK}$

H =  $t_{CCLK}$  (if a hold cycle is specified, else H = 0)

<sup>1</sup> On reset, ALE is an active high cycle. However, it can be reconfigured by software to be active low.

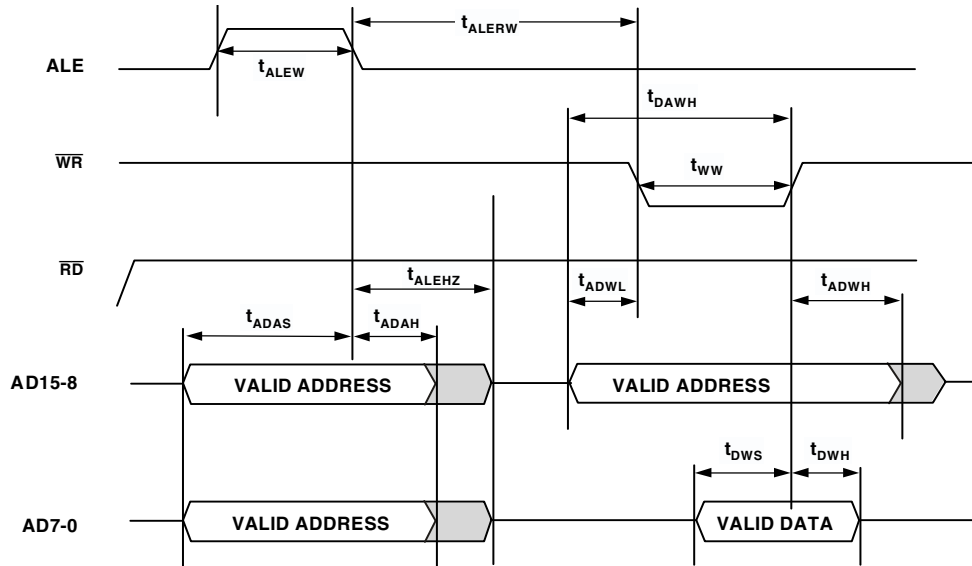

Figure 19. 8-Bit Memory Write Cycle

# ADSP-21261/ADSP-21262/ADSP-21266

Table 28. 16-Bit Memory Write Cycle

Parameter		Min	Max	Unit
<i>Switching Characteristics</i>				
$t_{ALEW}$	ALE Pulse Width	$2 \times t_{CCLK} - 2$		ns
$t_{ALERW}$	ALE Deasserted to Read/Write Asserted	$1 \times t_{CCLK} - 0.5$		ns
$t_{ADAS}^1$	Address/Data 15–0 Setup Before ALE Deasserted	$2.5 \times t_{CCLK} - 2.0$		ns
$t_{ADAH}^1$	Address/Data 15–0 Hold After ALE Deasserted	$0.5 \times t_{CCLK} - 0.8$		ns
$t_{WW}$	$\overline{WR}$ Pulse Width	$D - 2$		ns
$t_{ALEHZ}^1$	ALE Deasserted to Address/Data 15–0 in High-Z	$0.5 \times t_{CCLK} - 0.8$	$0.5 \times t_{CCLK} + 2.0$	ns
$t_{DWS}$	Address/Data 15–0 Setup Before $\overline{WR}$ High	D		ns
$t_{DWH}$	Address/Data 15–0 Hold After $\overline{WR}$ High	$0.5 \times t_{CCLK} - 1.5 + H$		ns

D = (The value set by the PPDUR Bits (5–1) in the PPCTL register)  $\times t_{CCLK}$

H =  $t_{CCLK}$  (if a hold cycle is specified, else H = 0)

<sup>1</sup> On reset, ALE is an active high cycle. However, it can be reconfigured by software to be active low.

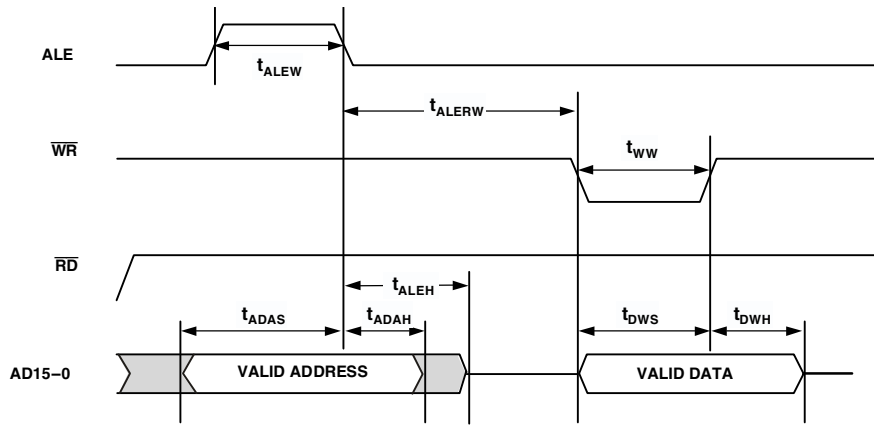

Figure 20. 16-Bit Memory Write Cycle

## Serial Ports

To determine whether communication is possible between two devices at a given clock speed, the specifications in [Table 29](#), [Table 30](#), [Table 31](#), [Table 32](#), [Figure 21](#), and [Figure 22](#) must be confirmed: 1) frame sync delay and frame sync setup and hold; 2) data delay and data setup and hold; and 3) SCLK width.

Serial port signals (SCLK, FS, DxA, DxB) are routed to the DAI\_P20–1 pins using the SRU. Therefore, the timing specifications provided below are valid at the DAI\_P20–1 pins.

**Table 29. Serial Ports—External Clock**

Parameter	Min	Max	Unit
<i>Timing Requirements</i>			
t <sub>SFSE</sub> FS Setup Before SCLK (Externally Generated FS in Either Transmit or Receive Mode) <sup>1</sup>	2.5		ns
t <sub>HFSE</sub> FS Hold After SCLK (Externally Generated FS in Either Transmit or Receive Mode) <sup>1</sup>	2.5		ns
t <sub>SDRE</sub> Receive Data Setup Before Receive SCLK <sup>1</sup>	2.5		ns
t <sub>HDRE</sub> Receive Data Hold After SCLK <sup>1</sup>	2.5		ns
t <sub>SCLKW</sub> SCLK Width	7		ns
t <sub>SCLK</sub> SCLK Period	20		ns
<i>Switching Characteristics</i>			
t <sub>DFSE</sub> FS Delay After SCLK (Internally Generated FS in Either Transmit or Receive Mode) <sup>2</sup>		7	ns
t <sub>HOFSE</sub> FS Hold After SCLK (Internally Generated FS in Either Transmit or Receive Mode) <sup>2</sup>	2		ns
t <sub>DDTE</sub> Transmit Data Delay After Transmit SCLK <sup>2</sup>		7	ns
t <sub>HDTE</sub> Transmit Data Hold After Transmit SCLK <sup>2</sup>	2		ns

<sup>1</sup>Referenced to sample edge.

<sup>2</sup>Referenced to drive edge.

**Table 30. Serial Ports—Internal Clock**

Parameter	Min	Max	Unit
<i>Timing Requirements</i>			
t <sub>SFSI</sub> FS Setup Before SCLK (Externally Generated FS in Either Transmit or Receive Mode) <sup>1</sup>	6		ns
t <sub>HFSI</sub> FS Hold After SCLK (Externally Generated FS in Either Transmit or Receive Mode) <sup>1</sup>	1.5		ns
t <sub>SDRI</sub> Receive Data Setup Before SCLK <sup>1</sup>	6		ns
t <sub>HDRI</sub> Receive Data Hold After SCLK <sup>1</sup>	1.5		ns
<i>Switching Characteristics</i>			
t <sub>DFSI</sub> FS Delay After SCLK (Internally Generated FS in Transmit Mode) <sup>2</sup>		3	ns
t <sub>HOFSI</sub> FS Hold After SCLK (Internally Generated FS in Transmit Mode) <sup>2</sup>	–1.0		ns
t <sub>DFSI</sub> FS Delay After SCLK (Internally Generated FS in Receive Mode) <sup>2</sup>		3	ns
t <sub>HOFSI</sub> FS Hold After SCLK (Internally Generated FS in Receive Mode) <sup>2</sup>	–1.0		ns
t <sub>DDTI</sub> Transmit Data Delay After SCLK <sup>2</sup>		3	ns
t <sub>HDTI</sub> Transmit Data Hold After SCLK <sup>2</sup>	–1.0		ns
t <sub>SCLKIW</sub> Transmit or Receive SCLK Width	0.5t <sub>SCLK</sub> – 2	0.5t <sub>SCLK</sub> + 2	ns

<sup>1</sup>Referenced to the sample edge.

<sup>2</sup>Referenced to drive edge.

# ADSP-21261/ADSP-21262/ADSP-21266

**Table 31. Serial Ports—Enable and Three-State**

Parameter		Min	Max	Unit
<i>Switching Characteristics</i>				
$t_{DDTEN}$	Data Enable from External Transmit SCLK <sup>1</sup>	2		ns
$t_{DDTTE}$	Data Disable from External Transmit SCLK <sup>1</sup>		7	ns
$t_{DDTIN}$	Data Enable from Internal Transmit SCLK <sup>1</sup>	-1		ns

<sup>1</sup>Referenced to drive edge.

**Table 32. Serial Ports—External Late Frame Sync**

Parameter		Min	Max	Unit
<i>Switching Characteristics</i>				
$t_{DDTLFSE}$	Data Delay from Late External Transmit FS or External Receive FS with MCE = 1, MFD = 0 <sup>1</sup>		7	ns
$t_{DDTENFS}$	Data Enable for MCE = 1, MFD = 0 <sup>1</sup>	0.5		ns

<sup>1</sup>The  $t_{DDTLFSE}$  and  $t_{DDTENFS}$  parameters apply to left-justified sample pair mode as well as DSP serial mode, and MCE = 1, MFD = 0.

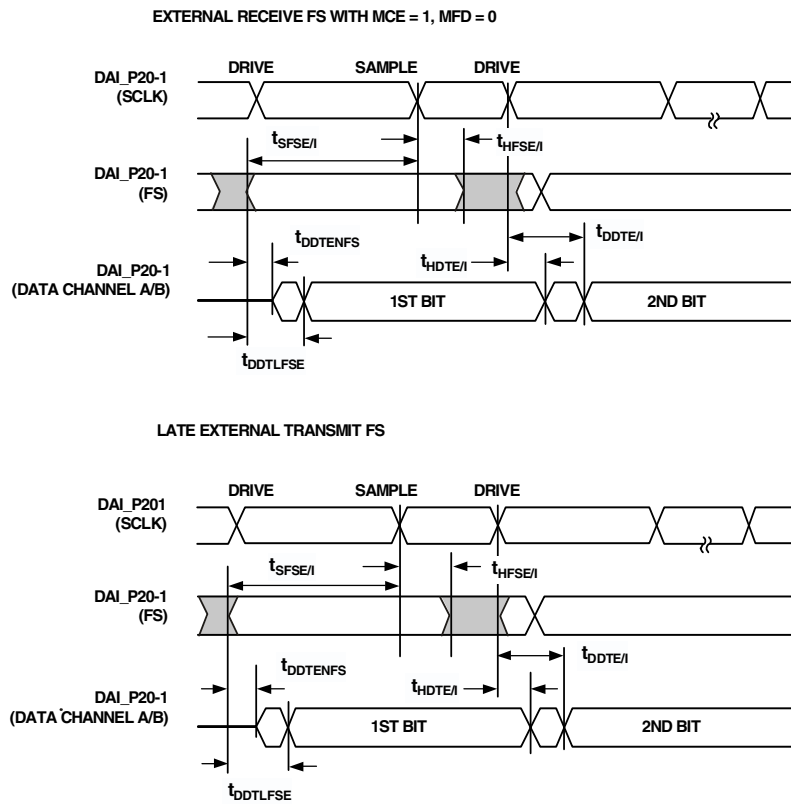

NOTE: SERIAL PORT SIGNALS (SCLK, FS, DATA CHANNEL A/B) ARE ROUTED TO THE DAI\_P[20:1] PINS USING THE SRU. THE TIMING SPECIFICATIONS PROVIDED HERE ARE VALID AT THE DAI\_P[20:1] PINS.

Figure 21. External Late Frame Sync<sup>1</sup>

<sup>1</sup>This figure reflects changes made to support left-justified sample pair mode.



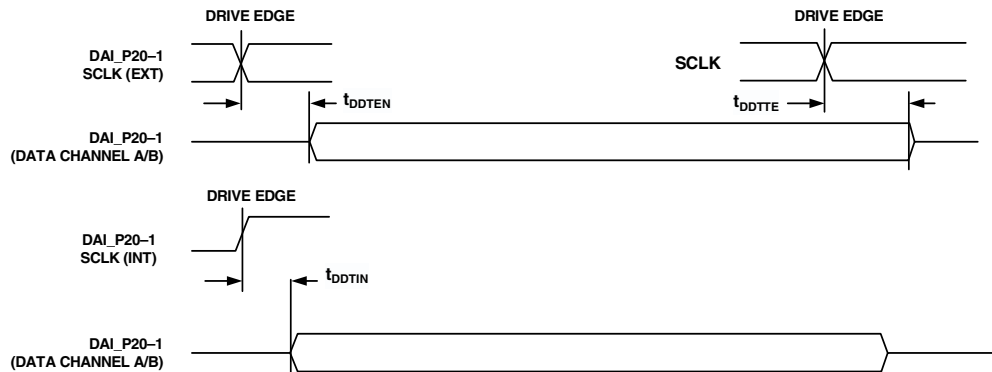
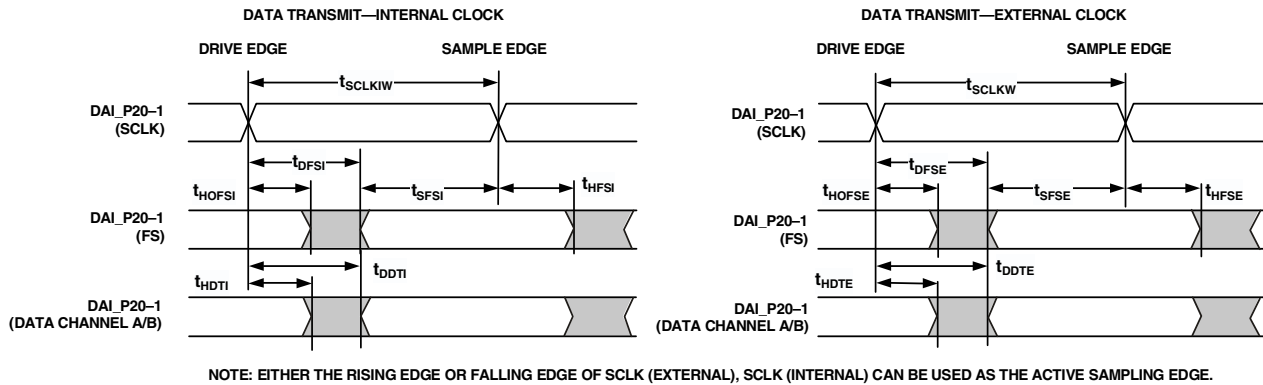
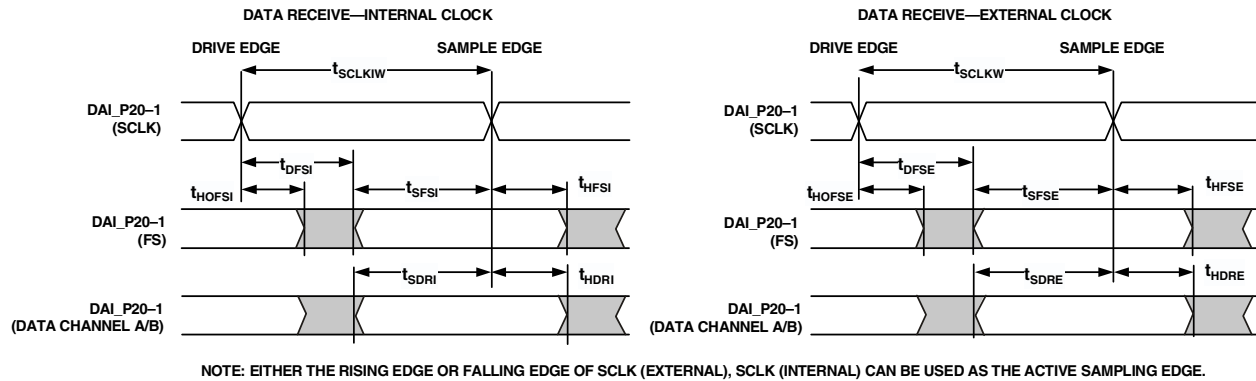

Figure 22. Serial Ports

# ADSP-21261/ADSP-21262/ADSP-21266

## Input Data Port (IDP)

The timing requirements for the IDP are given in [Table 33](#) and [Figure 23](#). IDP Signals (SCLK, FS, SDATA) are routed to the DAI\_P20-1 pins using the SRU. Therefore, the timing specifications provided below are valid at the DAI\_P20-1 pins.

**Table 33. Input Data Port (IDP)**

Parameter	Min	Max	Unit
<i>Timing Requirements</i>			
$t_{SISFS}$ FS Setup Before SCLK Rising Edge <sup>1</sup>	2.5		ns
$t_{SIHFS}$ FS Hold After SCLK Rising Edge <sup>1</sup>	2.5		ns
$t_{SISD}$ SDATA Setup Before SCLK Rising Edge <sup>1</sup>	2.5		ns
$t_{SIHD}$ SDATA Hold After SCLK Rising Edge <sup>1</sup>	2.5		ns
$t_{IDPCLKW}$ Clock Width	7		ns
$t_{IDPCLK}$ Clock Period	20		ns

<sup>1</sup> DATA, SCLK, FS can come from any of the DAI pins. SCLK and FS can also come via the precision clock generators (PCG) or SPORTs. PCG input can be either CLKIN or any of the DAI pins.

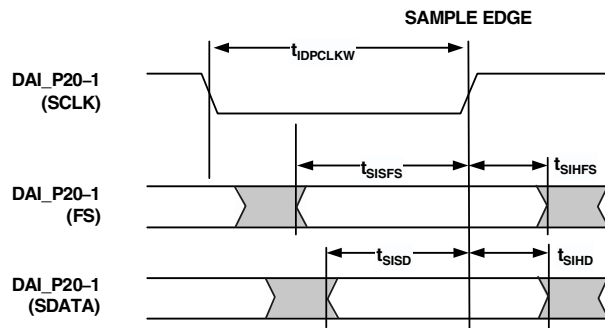

Figure 23. Input Data Port (IDP)

## Parallel Data Acquisition Port (PDAP)

The timing requirements for the PDAP are provided in [Table 34](#) and [Figure 24](#). PDAP is the parallel mode operation of Channel 0 of the IDP. For details on the operation of the IDP, see the IDP chapter of the *ADSP-2126x Peripherals Manual*.

Note that the most significant 16 bits of external PDAP data can be provided through either the parallel port AD15–0 or the DAI\_P20–5 pins. The remaining four bits can only be sourced through DAI\_P4–1. The timing below is valid at the DAI\_P20–1 pins or at the AD15–0 pins.

**Table 34. Parallel Data Acquisition Port (PDAP)**

Parameter		Min	Max	Unit
<i>Timing Requirements</i>				
$t_{SPCLKEN}$	PDAP_CLKEN Setup Before PDAP_CLK Sample Edge <sup>1</sup>	2.5		ns
$t_{HPCLKEN}$	PDAP_CLKEN Hold After PDAP_CLK Sample Edge <sup>1</sup>	2.5		ns
$t_{PDSD}$	PDAP_DAT Setup Before SCLK PDAP_CLK Sample Edge <sup>1</sup>	2.5		ns
$t_{PDHD}$	PDAP_DAT Hold After SCLK PDAP_CLK Sample Edge <sup>1</sup>	2.5		ns
$t_{PDCLKW}$	Clock Width	7		ns
$t_{PDCLK}$	Clock Period	20		ns
<i>Switching Characteristics</i>				
$t_{PDHLDD}$	Delay of PDAP Strobe After Last PDAP_CLK Capture Edge for a Word	$2 \times t_{CCLK}$		ns
$t_{PDSTRB}$	PDAP Strobe Pulse Width	$1 \times t_{CCLK} - 1$		ns

<sup>1</sup> Source pins of DATA are ADDR7–0, DATA7–0, or DAI pins. Source pins for SCLK and FS are: 1) DAI pins, 2) CLKIN through PCG, or 3) DAI pins through PCG.

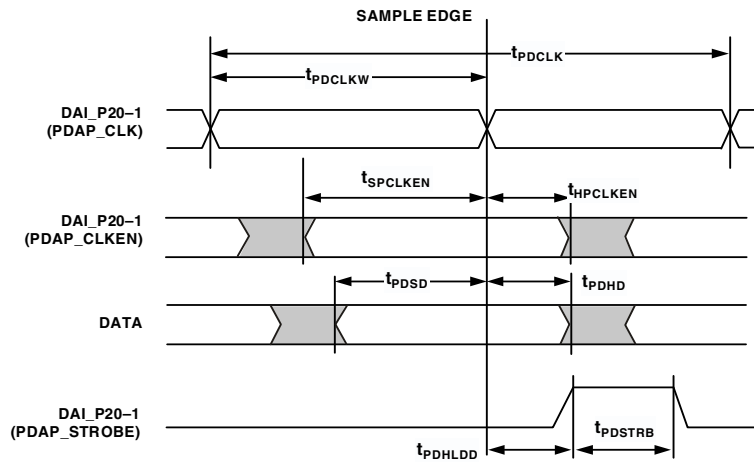

Figure 24. Parallel Data Acquisition Port (PDAP)

# ADSP-21261/ADSP-21262/ADSP-21266

## SPI Interface Protocol—Master

Table 35. SPI Interface Protocol—Master

Parameter		Min	Max	Unit
<i>Timing Requirements</i>				
$t_{SSPIDM}$	Data Input Valid to SPICLK Edge (Data Input Setup Time)	5		ns
$t_{HSPIDM}$	SPICLK Last Sampling Edge to Data Input Not Valid	2		ns
<i>Switching Characteristics</i>				
$t_{SPICLKM}$	Serial Clock Cycle	$8 \times t_{CCLK}$		ns
$t_{SPICHM}$	Serial Clock High Period	$4 \times t_{CCLK} - 2$		ns
$t_{SPICLM}$	Serial Clock Low Period	$4 \times t_{CCLK} - 2$		ns
$t_{DDSPIDM}$	SPICLK Edge to Data Out Valid (Data Out Delay Time)		3	ns
$t_{HDSPIDM}$	SPICLK Edge to Data Out Not Valid (Data Out Hold Time)	10		ns
$t_{SDSCIM}$	FLAG3-0 OUT (SPI Device Select) Low to First SPICLK Edge	$4 \times t_{CCLK} - 2$		ns
$t_{HDSM}$	Last SPICLK Edge to FLAG3-0 OUT High	$4 \times t_{CCLK} - 1$		ns
$t_{SPITDM}$	Sequential Transfer Delay	$4 \times t_{CCLK} - 1$		ns

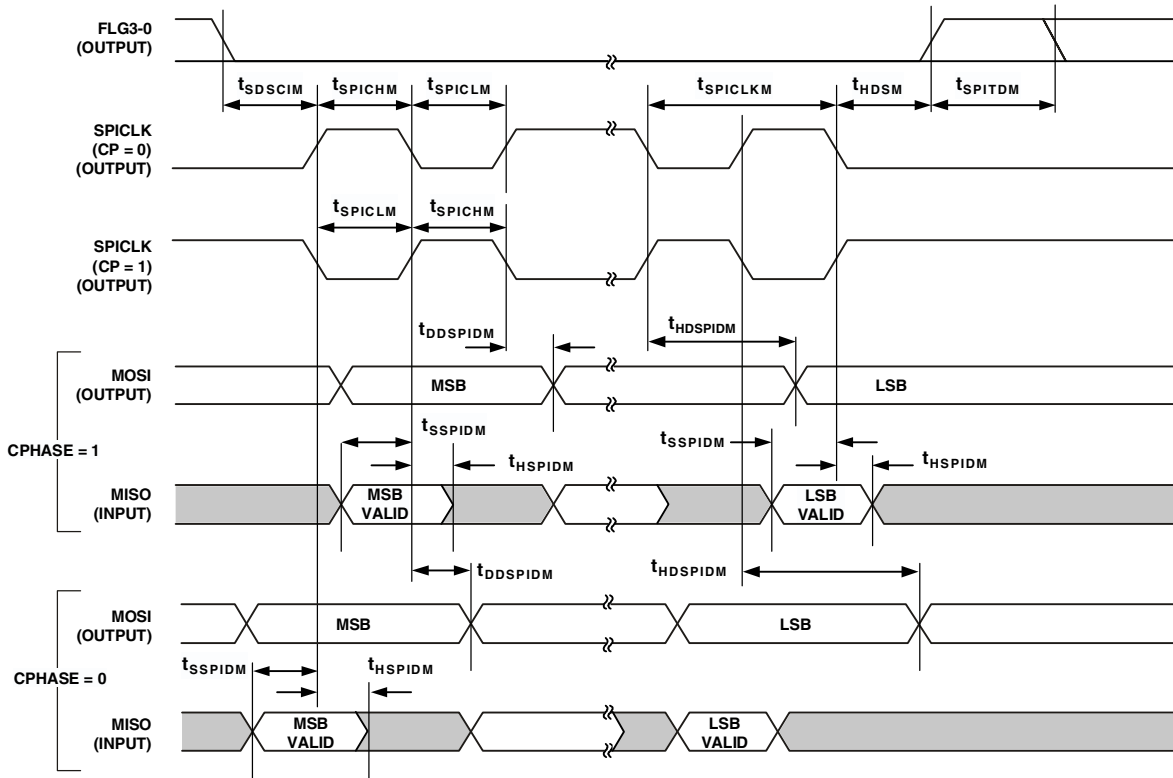

Figure 25. SPI Interface Protocol—Master

## SPI Interface Protocol—Slave

Table 36. SPI Interface Protocol—Slave

Parameter		Min	Max	Unit
<i>Timing Requirements</i>				
$t_{SPICLKS}$	Serial Clock Cycle	$4 \times t_{CCLK}$		ns
$t_{SPICHS}$	Serial Clock High Period	$2 \times t_{CCLK} - 2$		ns
$t_{SPICLS}$	Serial Clock Low Period	$2 \times t_{CCLK} - 2$		ns
$t_{SDSCO}$	$\overline{SPIDS}$ Assertion to First SPICLK Edge			
	CPHASE = 0	$2 \times t_{CCLK} + 1$		ns
	CPHASE = 1	$2 \times t_{CCLK} + 1$		ns
$t_{HDS}$	Last SPICLK Edge to $\overline{SPIDS}$ Not Asserted CPHASE = 0	$2 \times t_{CCLK}$		ns
$t_{SSPIDS}$	Data Input Valid to SPICLK Edge (Data Input Setup Time)	2		ns
$t_{HSPIDS}$	SPICLK Last Sampling Edge to Data Input Not Valid	2		ns
$t_{SDPPW}$	$\overline{SPIDS}$ Deassertion Pulse Width (CPHASE = 0)	$2 \times t_{CCLK}$		ns
<i>Switching Characteristics</i>				
$t_{DSOE}$	$\overline{SPIDS}$ Assertion to Data Out Active	0	5	ns
$t_{DSDHI}$	$\overline{SPIDS}$ Deassertion to Data High Impedance	0	5	ns
$t_{DDSPIDS}$	SPICLK Edge to Data Out Valid (Data Out Delay Time)		7.5	ns
$t_{HDSPIDS}$	SPICLK Edge to Data Out Not Valid (Data Out Hold Time)	$2 \times t_{CCLK} - 2$		ns
$t_{DSOV}$	$\overline{SPIDS}$ Assertion to Data Out Valid (CPHASE = 0)		$5 \times t_{CCLK} + 2$	ns

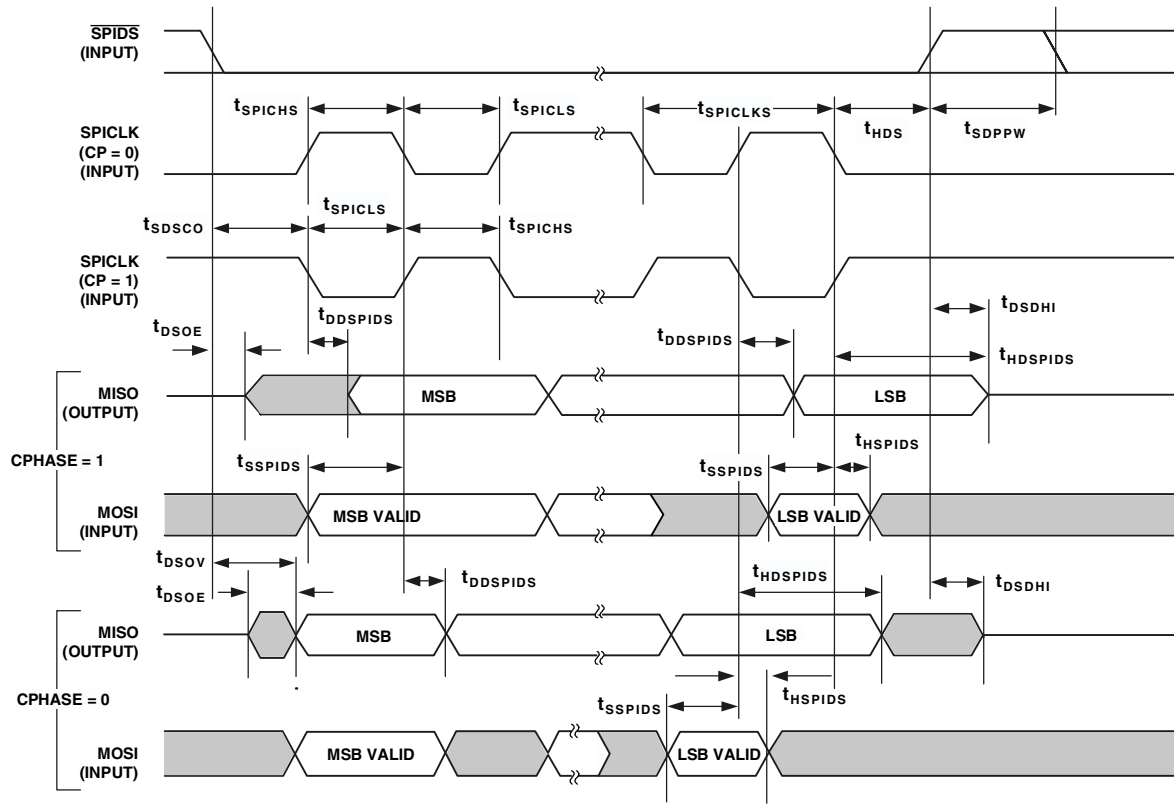

Figure 26. SPI Interface Protocol—Slave

# ADSP-21261/ADSP-21262/ADSP-21266

## JTAG Test Access Port and Emulation

Table 37. JTAG Test Access Port and Emulation

Parameter	Min	Max	Unit
<i>Timing Requirements</i>			
$t_{TCK}$ TCK Period	20		ns
$t_{STAP}$ TDI, TMS Setup Before TCK High	5		ns
$t_{HTAP}$ TDI, TMS Hold After TCK High	6		ns
$t_{SSYS}$ System Inputs Setup Before TCK High <sup>1</sup>	7		ns
$t_{HSYS}$ System <sup>2</sup> Inputs Hold After TCK High <sup>1</sup>			ns
$t_{TRSTW}$ $\overline{TRST}$ Pulse Width	$4 \times t_{CK}$		ns
<i>Switching Characteristics</i>			
$t_{DTDO}$ TDO Delay from TCK Low		7	ns
$t_{DSYS}$ System Outputs Delay After TCK Low <sup>2</sup>		10	ns

<sup>1</sup>System Inputs = AD15-0,  $\overline{SPIDS}$ , CLK\_CFG1-0,  $\overline{RESET}$ ,  $\overline{BOOT\_CFG1-0}$ , MISO, MOSI, SPICLK, DAI\_Px, FLAG3-0.

<sup>2</sup>System Outputs = MISO, MOSI, SPICLK, DAI\_Px, AD15-0,  $\overline{RD}$ ,  $\overline{WR}$ , FLAG3-0, CLKOUT,  $\overline{EMU}$ , ALE.

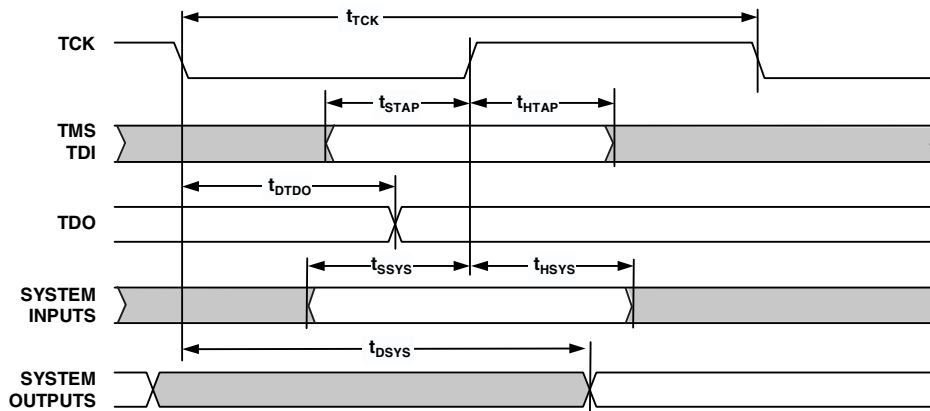

Figure 27. JTAG Test Access Port and Emulation

## OUTPUT DRIVE CURRENTS

Figure 28 shows typical I-V characteristics for the output drivers of the ADSP-2126x. The curves represent the current drive capability of the output drivers as a function of output voltage.

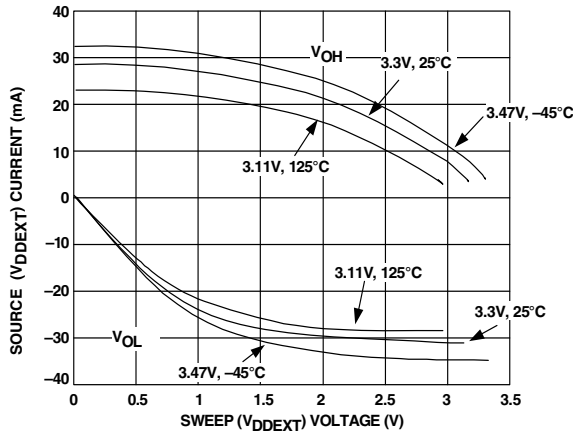

Figure 28. Typical Drive

## TEST CONDITIONS

The ac signal specifications (timing parameters) appear in Table 16 on Page 20 through Table 37 on Page 38. These include output disable time, output enable time, and capacitive loading.

Timing is measured on signals when they cross the 1.5 V level as described in Figure 30. All delays (in nanoseconds) are measured between the point that the first signal reaches 1.5 V and the point that the second signal reaches 1.5 V.

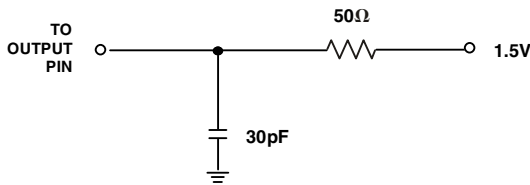

Figure 29. Equivalent Device Loading for AC Measurements (Includes All Fixtures)



Figure 30. Voltage Reference Levels for AC Measurements

## CAPACITIVE LOADING

Output delays and holds are based on standard capacitive loads: 30 pF on all pins (see Figure 29). Figure 32 shows graphically how output delays and holds vary with load capacitance (note that this graph or derating does not apply to output disable delays). The graphs of Figure 31, Figure 32, and Figure 33 may not be linear outside the ranges shown for Typical Output Delay vs. Load Capacitance and Typical Output Rise Time (20% to 80%, V = Min) vs. Load Capacitance.

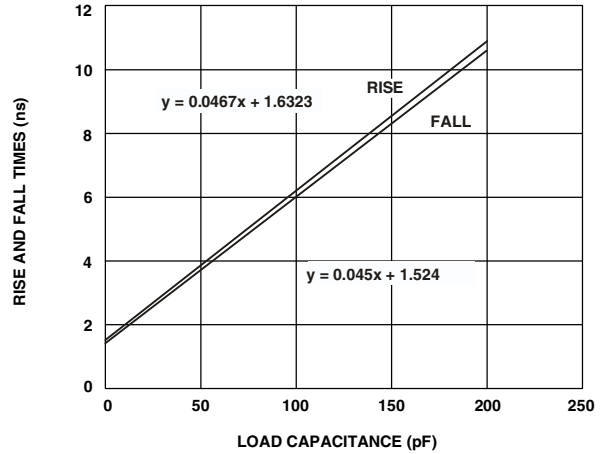

Figure 31. Typical Output Rise Time (20% to 80%,  $V_{DDEXT} = Max$ )

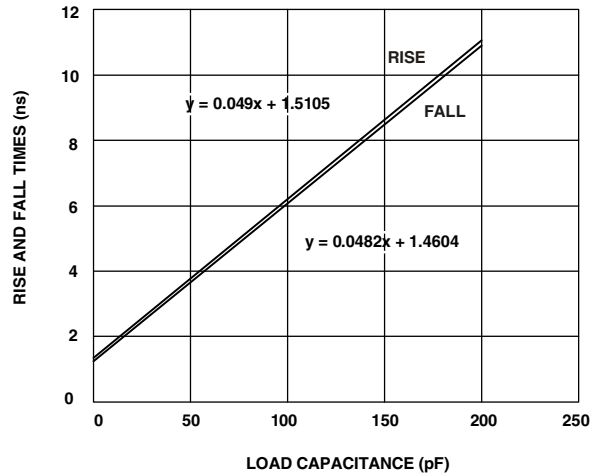

Figure 32. Typical Output Rise/Fall Time (20% to 80%,  $V_{DDEXT} = Min$ )

# ADSP-21261/ADSP-21262/ADSP-21266

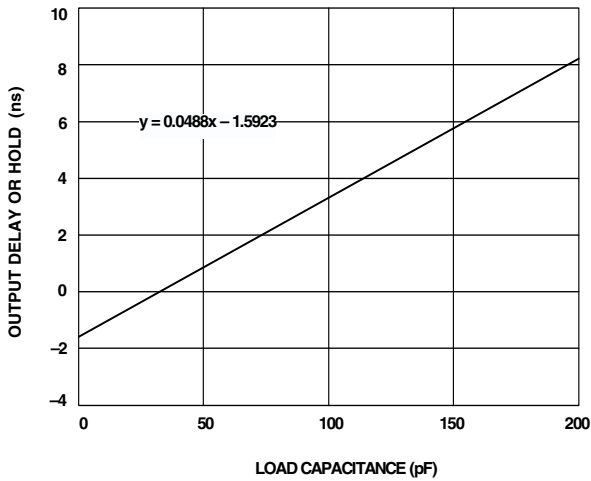

Figure 33. Typical Output Delay or Hold vs. Load Capacitance (at Ambient Temperature)

## ENVIRONMENTAL CONDITIONS

The ADSP-2126x processor is rated for performance under  $T_{AMB}$  environmental conditions specified in the [Operating Conditions on Page 16](#).

## THERMAL CHARACTERISTICS

[Table 38](#) and [Table 39](#) airflow measurements comply with JEDEC standards JESD51-2 and JESD51-6 and the junction-to-board measurement complies with JESD51-8. The junction-to-case measurement complies with MIL-STD-883. All measurements use a 2S2P JEDEC test board.

To determine the junction temperature of the device while on the application PCB, use

$$T_J = T_{CASE} + (\Psi_{JT} \times P_D)$$

where:

$T_J$  = junction temperature (°C)

$T_{CASE}$  = case temperature (°C) measured at the top center of the package

$\Psi_{JT}$  = junction-to-top (of package) characterization parameter is the typical value from [Table 38](#) and [Table 39](#) ( $\Psi_{JMT}$  indicates moving air).

$P_D$  = power dissipation. See *Estimating Power Dissipation for ADSP-21262 SHARC DSPs (EE-216)* for more information.

Values of  $\theta_{JA}$  are provided for package comparison and PCB design considerations ( $\theta_{JMA}$  indicates moving air).  $\theta_{JA}$  can be used for a first order approximation of  $T_J$  by the equation

$$T_J = T_A + (\theta_{JA} \times P_D)$$

where:

$T_A$  = ambient temperature °C

Values of  $\theta_{JC}$  are provided for package comparison and PCB design considerations when an external heat sink is required.

Table 38. Thermal Characteristics for 136-Ball BGA

Parameter	Condition	Typical	Unit
$\theta_{JA}$	Airflow = 0 m/s	31.0	°C/W
$\theta_{JMA}$	Airflow = 1 m/s	27.3	°C/W
$\theta_{JMA}$	Airflow = 2 m/s	26.0	°C/W
$\theta_{JC}$		6.99	°C/W
$\Psi_{JT}$	Airflow = 0 m/s	0.16	°C/W
$\Psi_{JMT}$	Airflow = 1 m/s	0.30	°C/W
$\Psi_{JMT}$	Airflow = 2 m/s	0.35	°C/W

Table 39. Thermal Characteristics for 144-Lead LQFP

Parameter	Condition	Typical	Unit
$\theta_{JA}$	Airflow = 0 m/s	32.5	°C/W
$\theta_{JMA}$	Airflow = 1 m/s	28.9	°C/W
$\theta_{JMA}$	Airflow = 2 m/s	27.8	°C/W
$\theta_{JC}$		7.8	°C/W
$\Psi_{JT}$	Airflow = 0 m/s	0.5	°C/W
$\Psi_{JMT}$	Airflow = 1 m/s	0.8	°C/W
$\Psi_{JMT}$	Airflow = 2 m/s	1.0	°C/W



## 144-LEAD LQFP PIN CONFIGURATIONS

Table 40 shows the ADSP-2126x's pin names and their default function after reset (in parentheses).

Table 40. 144-Lead LQFP Pin Assignments

Pin Name	LQFP Pin No.	Pin Name	LQFP Pin No.	Pin Name	LQFP Pin No.	Pin Name	LQFP Pin No.
V <sub>DDINT</sub>	1	V <sub>DDINT</sub>	37	V <sub>DDEXT</sub>	73	GND	109
CLK_CFG0	2	GND	38	GND	74	V <sub>DDINT</sub>	110
CLK_CFG1	3	$\overline{\text{RD}}$	39	V <sub>DDINT</sub>	75	GND	111
BOOT_CFG0	4	ALE	40	GND	76	V <sub>DDINT</sub>	112
BOOT_CFG1	5	AD15	41	DAI_P10 (SD2B)	77	GND	113
GND	6	AD14	42	DAI_P11 (SD3A)	78	V <sub>DDINT</sub>	114
V <sub>DDEXT</sub>	7	AD13	43	DAI_P12 (SD3B)	79	GND	115
GND	8	GND	44	DAI_P13 (SCLK23)	80	V <sub>DDEXT</sub>	116
V <sub>DDINT</sub>	9	V <sub>DDEXT</sub>	45	DAI_P14 (SFS23)	81	GND	117
GND	10	AD12	46	DAI_P15 (SD4A)	82	V <sub>DDINT</sub>	118
V <sub>DDINT</sub>	11	V <sub>DDINT</sub>	47	V <sub>DDINT</sub>	83	GND	119
GND	12	GND	48	GND	84	V <sub>DDINT</sub>	120
V <sub>DDINT</sub>	13	AD11	49	GND	85	$\overline{\text{RESET}}$	121
GND	14	AD10	50	DAI_P16 (SD4B)	86	$\overline{\text{SPIDS}}$	122
FLAG0	15	AD9	51	DAI_P17 (SD5A)	87	GND	123
FLAG1	16	AD8	52	DAI_P18 (SD5B)	88	V <sub>DDINT</sub>	124
AD7	17	DAI_P1 (SD0A)	53	DAI_P19 (SCLK45)	89	SPICLK	125
GND	18	V <sub>DDINT</sub>	54	V <sub>DDINT</sub>	90	MISO	126
V <sub>DDINT</sub>	19	GND	55	GND	91	MOSI	127
GND	20	DAI_P2 (SD0B)	56	GND	92	GND	128
V <sub>DDEXT</sub>	21	DAI_P3 (SCLK0)	57	V <sub>DDEXT</sub>	93	V <sub>DDINT</sub>	129
GND	22	GND	58	DAI_P20 (SFS45)	94	V <sub>DDEXT</sub>	130
V <sub>DDINT</sub>	23	V <sub>DDEXT</sub>	59	GND	95	A <sub>VDD</sub>	131
AD6	24	V <sub>DDINT</sub>	60	V <sub>DDINT</sub>	96	A <sub>VSS</sub>	132
AD5	25	GND	61	FLAG2	97	GND	133
AD4	26	DAI_P4 (SFS0)	62	FLAG3	98	$\overline{\text{RESETOUT/CLKOUT}}$	134
V <sub>DDINT</sub>	27	DAI_P5 (SD1A)	63	V <sub>DDINT</sub>	99	$\overline{\text{EMU}}$	135
GND	28	DAI_P6 (SD1B)	64	GND	100	TDO	136
AD3	29	DAI_P7 (SCLK1)	65	V <sub>DDINT</sub>	101	TDI	137
AD2	30	V <sub>DDINT</sub>	66	GND	102	$\overline{\text{TRST}}$	138
V <sub>DDEXT</sub>	31	GND	67	V <sub>DDINT</sub>	103	TCK	139
GND	32	V <sub>DDINT</sub>	68	GND	104	TMS	140
AD1	33	GND	69	V <sub>DDINT</sub>	105	GND	141
AD0	34	DAI_P8 (SFS1)	70	GND	106	CLKIN	142
$\overline{\text{WR}}$	35	DAI_P9 (SD2A)	71	V <sub>DDINT</sub>	107	XTAL	143
V <sub>DDINT</sub>	36	V <sub>DDINT</sub>	72	V <sub>DDINT</sub>	108	V <sub>DDEXT</sub>	144

# ADSP-21261/ADSP-21262/ADSP-21266

## 136-BALL BGA PIN CONFIGURATIONS

Table 41 shows the ADSP-2126x's pin names and their default function after reset (in parentheses). Figure 34 on Page 44 shows the BGA package pin assignments.

Table 41. 136-Ball BGA Pin Assignments

Pin Name	BGA Pin No.	Pin Name	BGA Pin No.	Pin Name	BGA Pin No.	Pin Name	BGA Pin No.
CLK_CFG0	A01	CLK_CFG1	B01	BOOT_CFG1	C01	V <sub>DDINT</sub>	D01
XTAL	A02	GND	B02	BOOT_CFG0	C02	GND	D02
TMS	A03	V <sub>DDEXT</sub>	B03	GND	C03	GND	D04
TCK	A04	CLKIN	B04	GND	C12	GND	D05
TDI	A05	$\overline{\text{TRST}}$	B05	GND	C13	GND	D06
$\overline{\text{RESETOUT}}/\text{CLKOUT}$	A06	A <sub>VSS</sub>	B06	V <sub>DDINT</sub>	C14	GND	D09
TDO	A07	A <sub>VDD</sub>	B07			GND	D10
$\overline{\text{EMU}}$	A08	V <sub>DDEXT</sub>	B08			GND	D11
MOSI	A09	SPICLK	B09			GND	D13
MISO	A10	$\overline{\text{RESET}}$	B10			V <sub>DDINT</sub>	D14
$\overline{\text{SPIDS}}$	A11	V <sub>DDINT</sub>	B11				
V <sub>DDINT</sub>	A12	GND	B12				
GND	A13	GND	B13				
GND	A14	GND	B14				
V <sub>DDINT</sub>	E01	FLAG1	F01	AD7	G01	AD6	H01
GND	E02	FLAG0	F02	V <sub>DDINT</sub>	G02	V <sub>DDEXT</sub>	H02
GND	E04	GND	F04	V <sub>DDEXT</sub>	G13	DAI_P18 (SD5B)	H13
GND	E05	GND	F05	DAI_P19 (SCLK45)	G14	DAI_P17 (SD5A)	H14
GND	E06	GND	F06				
GND	E09	GND	F09				
GND	E10	GND	F10				
GND	E11	GND	F11				
GND	E13	FLAG2	F13				
FLAG3	E14	DAI_P20 (SFS45)	F14				

**Table 41. 136-Ball BGA Pin Assignments (Continued)**

Pin Name	BGA Pin No.	Pin Name	BGA Pin No.	Pin Name	BGA Pin No.	Pin Name	BGA Pin No.
AD5	J01	AD3	K01	AD2	L01	AD0	M01
AD4	J02	V <sub>DDINT</sub>	K02	AD1	L02	$\overline{\text{WR}}$	M02
GND	J04	GND	K04	GND	L04	GND	M03
GND	J05	GND	K05	GND	L05	GND	M12
GND	J06	GND	K06	GND	L06	DAI_P12 (SD3B)	M13
GND	J09	GND	K09	GND	L09	DAI_P13 (SCLK23)	M14
GND	J10	GND	K10	GND	L10		
GND	J11	GND	K11	GND	L11		
V <sub>DDINT</sub>	J13	GND	K13	GND	L13		
DAI_P16 (SD4B)	J14	DAI_P15 (SD4A)	K14	DAI_P14 (SFS23)	L14		
AD15	N01	AD14	P01				
ALE	N02	AD13	P02				
$\overline{\text{RD}}$	N03	AD12	P03				
V <sub>DDINT</sub>	N04	AD11	P04				
V <sub>DDEXT</sub>	N05	AD10	P05				
AD8	N06	AD9	P06				
V <sub>DDINT</sub>	N07	DAI_P1 (SD0A)	P07				
DAI_P2 (SD0B)	N08	DAI_P3 (SCLK0)	P08				
V <sub>DDEXT</sub>	N09	DAI_P5 (SD1A)	P09				
DAI_P4 (SFS0)	N10	DAI_P6 (SD1B)	P10				
V <sub>DDINT</sub>	N11	DAI_P7 (SCLK1)	P11				
V <sub>DDINT</sub>	N12	DAI_P8 (SFS1)	P12				
GND	N13	DAI_P9 (SD2A)	P13				
DAI_P10 (SD2B)	N14	DAI_P11 (SD3A)	P14				

# ADSP-21261/ADSP-21262/ADSP-21266

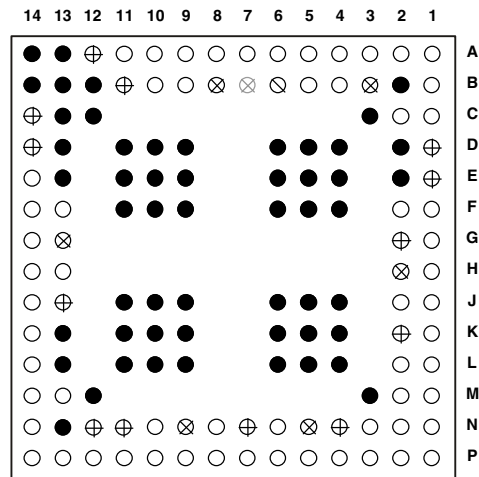

## KEY

⊕	V <sub>DDINT</sub>	●	GND*	⊗	A <sub>VDD</sub>
⊗	V <sub>DDEXT</sub>	⊗	A <sub>VSS</sub>	○	I/O SIGNALS

\*USE THE CENTER BLOCK OF GROUND PINS TO PROVIDE THERMAL PATHWAYS TO YOUR PRINTED CIRCUIT BOARD'S GROUND PLANE.

Figure 34. 136-Ball BGA Pin Assignments (Bottom View, Summary)

## OUTLINE DIMENSIONS

The ADSP-2126x is available in a 136-ball BGA package and a 144-lead LQFP package shown in [Figure 36](#) and [Figure 35](#).

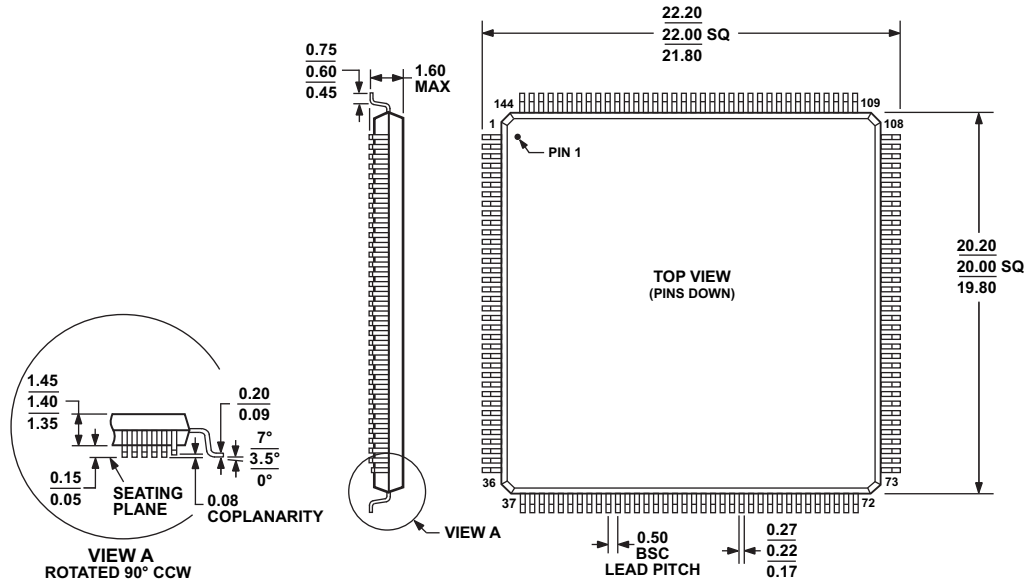

COMPLIANT TO JEDEC STANDARDS MS-026-BFB

Figure 35. 144-Lead Low Profile Flat Package [LQFP] (ST-144)

Dimensions shown in millimeters

# ADSP-21261/ADSP-21262/ADSP-21266

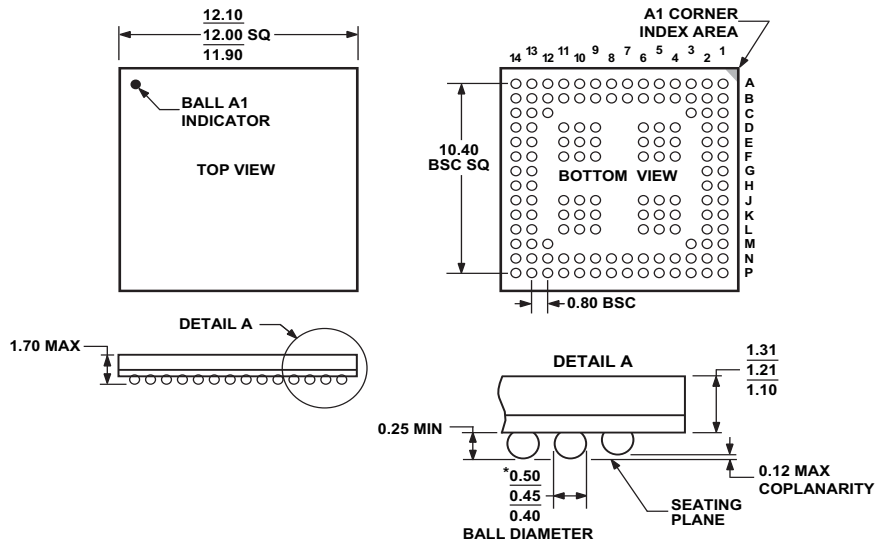

\*COMPLIANT WITH JEDEC STANDARDS MO-205-AE WITH EXCEPTION TO BALL DIAMETER.

Figure 36. 136-Ball Chip Scale Package Ball Grid Array [CSP\_BGA] (BC-136)

Dimensions shown in millimeters

## SURFACE-MOUNT DESIGN

Table 42 is provided as an aide to PCB design. For industry-standard design recommendations, refer to IPC-7351, *Generic Requirements for Surface-Mount Design and Land Pattern Standard*.

Table 42. BGA\_ED Data for Use with Surface-Mount Design

Package	Ball Attach Type	Solder Mask Opening	Ball Pad Size
136-Ball CSP_BGA (BC-136)	Solder Mask Defined (SMD)	0.4 mm	0.53 mm

## ORDERING GUIDE

Analog Devices offers a wide variety of audio algorithms and combinations to run on the ADSP-21266 DSP. For a complete list, visit our website at [www.analog.com/SHARC](http://www.analog.com/SHARC).

Model	Temperature Range <sup>1</sup>	Instruction Rate	On-Chip SRAM	ROM	Operating Voltage Internal/External	Package Description	Package Option
ADSP-21261SKBC-150	0°C to +70°C	150 MHz	1M bit	3M bit	1.2 V/3.3 V	136-Ball CSP_BGA	BC-136
ADSP-21261SKBCZ150 <sup>2</sup>	0°C to +70°C	150 MHz	1M bit	3M bit	1.2 V/3.3 V	136-Ball CSP_BGA	BC-136
ADSP-21261SKSTZ150 <sup>2</sup>	0°C to +70°C	150 MHz	1M bit	3M bit	1.2 V/3.3 V	144-Lead LQFP	ST-144
ADSP-21262SBBC-150	0°C to +70°C	150 MHz	2M bit	4M bit	1.2 V/3.3 V	136-Ball CSP_BGA	BC-136
ADSP-21262SBBCZ150 <sup>2</sup>	0°C to +70°C	150 MHz	2M bit	4M bit	1.2 V/3.3 V	136-Ball CSP_BGA	BC-136
ADSP-21262SKBC-200	0°C to +70°C	200 MHz	2M bit	4M bit	1.2 V/3.3 V	136-Ball CSP_BGA	BC-136
ADSP-21262SKBCZ200 <sup>2</sup>	0°C to +70°C	200 MHz	2M bit	4M bit	1.2 V/3.3 V	136-Ball CSP_BGA	BC-136
ADSP-21262SKSTZ200 <sup>2</sup>	0°C to +70°C	200 MHz	2M bit	4M bit	1.2 V/3.3 V	144-Lead LQFP	ST-144
ADSP-21266SKSTZ-1B <sup>2,3</sup>	0°C to +70°C	150 MHz	2M bit	4M bit	1.2 V/3.3 V	144-Lead LQFP	ST-144
ADSP-21266SKSTZ-2B <sup>2,3</sup>	0°C to +70°C	200 MHz	2M bit	4M bit	1.2 V/3.3 V	144-Lead LQFP	ST-144
ADSP-21266SKBCZ-2B <sup>2,3</sup>	0°C to +70°C	200 MHz	2M bit	4M bit	1.2 V/3.3 V	136-Ball CSP_BGA	BC-136
ADSP-21266SKSTZ-1C <sup>2,4</sup>	0°C to +70°C	150 MHz	2M bit	4M bit	1.2 V/3.3 V	144-Lead LQFP	ST-144
ADSP-21266SKSTZ-2C <sup>2,4</sup>	0°C to +70°C	200 MHz	2M bit	4M bit	1.2 V/3.3 V	144-Lead LQFP	ST-144
ADSP-21266SKBCZ-2C <sup>2,4</sup>	0°C to +70°C	200 MHz	2M bit	4M bit	1.2 V/3.3 V	136-Ball CSP_BGA	BC-136
ADSP-21266SKSTZ-1D <sup>2,4</sup>	0°C to +70°C	150 MHz	2M bit	4M bit	1.2 V/3.3 V	144-Lead LQFP	ST-144
ADSP-21266SKSTZ-2D <sup>2,4</sup>	0°C to +70°C	200 MHz	2M bit	4M bit	1.2 V/3.3 V	144-Lead LQFP	ST-144
ADSP-21266SKBCZ-2D <sup>2,4</sup>	0°C to +70°C	200 MHz	2M bit	4M bit	1.2 V/3.3 V	136-Ball CSP_BGA	BC-136

<sup>1</sup>Referenced temperature is ambient temperature.

<sup>2</sup>Z = RoHS Compliant Part.

<sup>3</sup>B at end of part number indicates Rev. 0.1 silicon. See [Table 3 on Page 6](#) for multichannel surround sound decoder algorithms in on-chip B ROM.

<sup>4</sup>C and D at end of part number indicate Rev. 0.2 silicon. See [Table 3 on Page 6](#) for multichannel surround sound decoder algorithms in on-chip C and D ROM.

